

optional full stainless steel version

Hysteresis magnetic coupling

with collet clamps

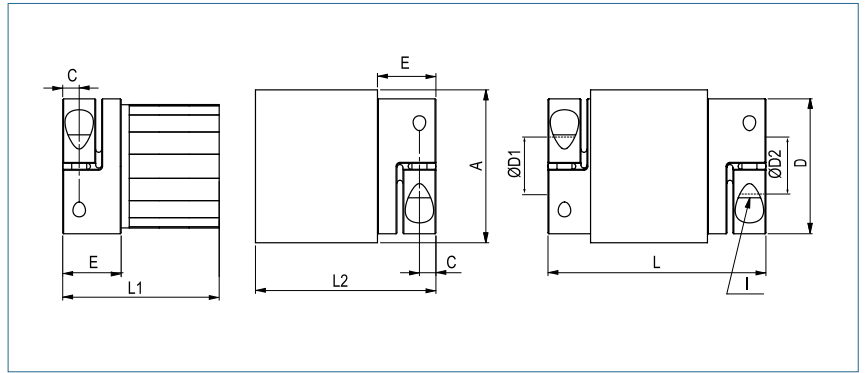

Order Code

HMK - 18 - 16 - 20

Type Size ØD1 (H7) ØD2 (H7)

Size	Torque TKN (Nm)	Dimensions (mm)										Technical Data						
		L	Ø A	D1/D2	L1	L2	H	C	E		I	Mass Innerpart (kg)	Mass Outerpart (kg)	Inertia Innerpart (g m ²)	Inertia Outerpart (g m ²)	Misalignment radial ΔKr (mm)	max speed min-1	
		Length	Outer	Bore Size (H7) min-max						Magnet-length	Hub Ø	Screw (ISO4762) TA (Nm)						
2	0.1	55	31	3-14	39	41	9	3.5	11	20	25	M3 2	0.07	0.11	0.005	0.018	0.2	10000
4	0.2	58	38	6-18	40	42	12	5	13	20	32.5	M4 3.5	0.11	0.15	0.01	0.04	0.2	9000
10	0.4	58	46	6-25	39.5	41.5	15.5	5	13.5	20	40.5	M4 4.5	0.16	0.2	0.04	0.08	0.2	8000
18	0.9	78	51	10-25.4	53.5	58.5	17	5.5	19.5	30	45	M5 8	0.23	0.28	0.07	0.14	0.2	7000
30	1.2	88	56	10-32	58.5	63.5	20	7.5	24.5	30	56	M6 15	0.28	0.35	0.1	0.21	0.2	6000
60	2.5	107	67	12-35	73	78	23	10	29	40	66	M8 40	0.53	0.7	0.3	0.6	0.2	5000
150	5	130	84	12-44	91.5	93.5	28	11	33.5	50	82	M10 84	0.9	1.5	1.1	1.3	0.2	4000

Material	Clamping hub: aluminium Magnetic media: stainless steel
Keyway	optional acc. DIN 6885
Range of temperature	-30 °C ~ 100 °C
Power dissipation	$P_v = (T \times n_g) / 9.55$

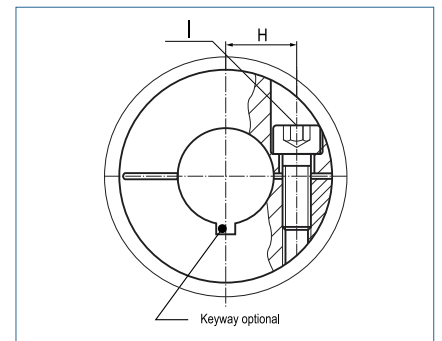

Characteristics	wear-free maintenance-free The coupling consists of 2 separated halves; the bearing has to be provided by the customer Infinitely variable torque adjustable by immersion depth In case of overload the power transmission will be separated from the inner and outer part (by slightly jerking)
------------------------	--

max. Power dissipation							
Size	2	4	10	18	30	60	150
P_{VMAX}	4	5	7	12	14	20	30