

Electromechanical actuators





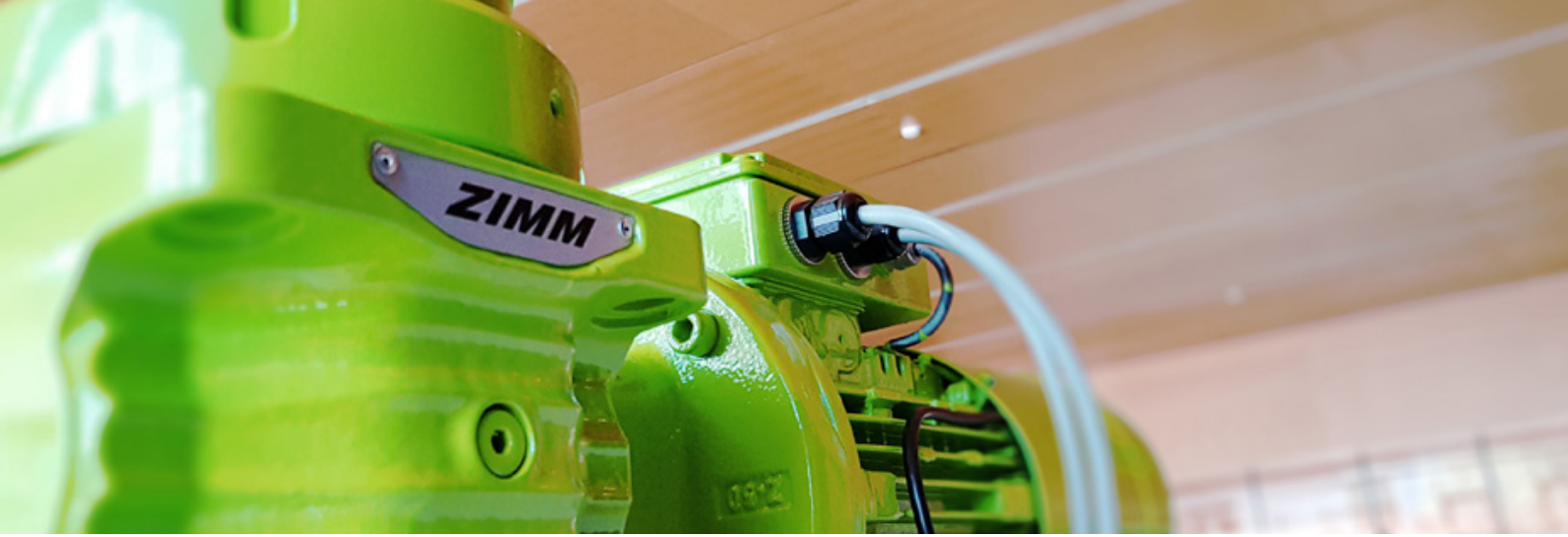

Table of contents

ZIMM Actuator Product Catalogue 2023 | 1.0

Actuator benefits	4 - 5
Electromechanical Actuators	
Actuator size 25 kN	6 - 7
Actuator size 50 kN	8 - 9
Actuator size 100 kN	10 - 11
Actuator size 200 kN	12 - 13
Accessories - ZIMM modular system	
Fixing flange & Connections	15
Pivoting	16 - 17
Handwheel & Protective cap	18
Motor flange	19
Three-phase AC motors	20 - 25
Connecting shafts	26 - 27
Pedestal bearing	28 - 29
Couplings	
Standard coupling	30 - 31
Clamp coupling	32 - 33
Bevel gearboxes	
Motor flange combinations	34 - 35
Motor flange combinations	37
Technical information	
Innovative, separate lubrication	38
Permissible loads attachments & installation	39
About ZIMM	
Movement with precision	40
The top 5 arguments for ZIMM	41
Screw jack assortment	42 - 43

ZIMM electromechanical Actuators

Clean, precise and sustainable



Precision in a new dimension

Accurate in every application, exact repeatability.

Strong in environmental protection

No hydraulic oil leaks and no special disposal.

Suitable for compression and tension

Can be used for changing loads. One design for compression, tension and alternating loads. Modifications are possible at any time.

Integrated pivot bushes

Matching bearing blocks, as standard.

Corrosion protection ex works

Consistent basic protection as standard, further protection levels and custom colours are possible.

Compact and slim design

No hoses, valves, pumps, tank and oil.

Low assembly costs

Simple modular system supplied ready for assembly - instead of time-consuming hydraulic assembly. Standardised flanges and mounting parts.

Lower noise level

Quiet electric motor instead of loud power unit.

ZIMM modular system

ZIMM offers complete drive systems with matching parts like safety solutions, fixing solutions, connecting shafts, couplings, bearing brackets for swivelling, common flanges, motors and protective device.





Contemporary drive technology

- » Improved material utilisation compared to hydraulic solutions
- » Easy maintenance
- » Higher energy efficiency
- » Time-saving assembly

25 kN

ZA-25 | Electromechanical actuators

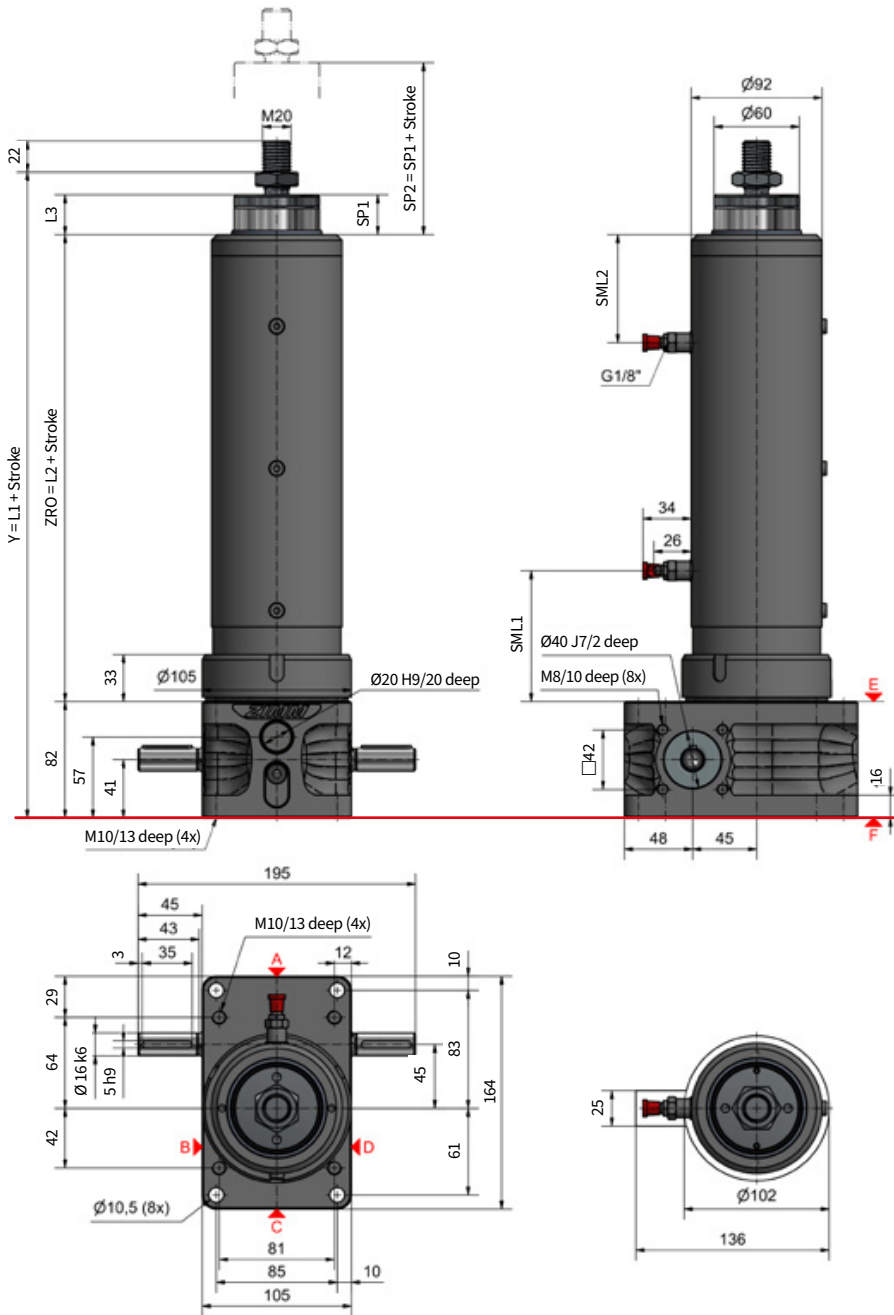

Standard configuration

Code	Ratio	Screw	Stroke per drive shaft rotation
ZA-25	24:1	Tr30x6	0,25 mm
		Tr40x7	0,29 mm
	6:1	Tr30x6	1,00 mm
		Tr40x7	1,17 mm
	24:1	KGT32x5	0,21 mm
		KGT32x10	0,42 mm
	6:1	KGT32x5	0,83 mm
		KGT32x10	1,67 mm
		KGT32x20	3,33 mm

Length calculations

	Standard TR mm	SIFA TR mm	KGT32x5 mm	KGT32x10 mm	KGT32x20 mm
L1	306	313	349	364	409
L2	185	192	224	234	264
L3	23	23	27	32	47
SP1	23	23	27	32	47
SML1	72	79	105	110	125
SML2	113	113	119	124	139

Lubrication position SP1 corresponds to standard lubrication length SML1
Safety distance L3.

For the lubrication of the screw drive and the anti-rotation lock, the lubrication positions lubrication positions SP1 (retracted) and SP2 (extended) must be maintained at ± 2 mm.

Technical information

ZA-25 | Critical buckling force & critical whirling speed

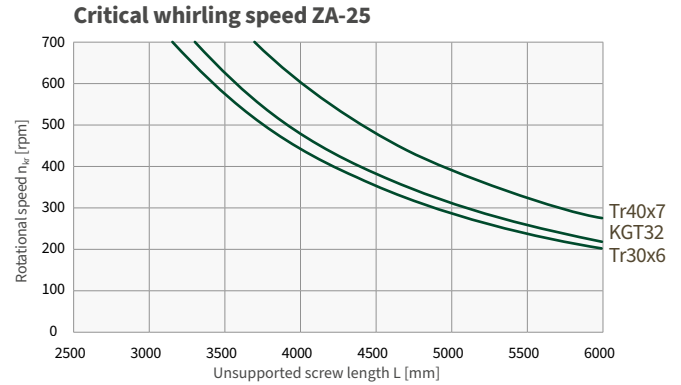
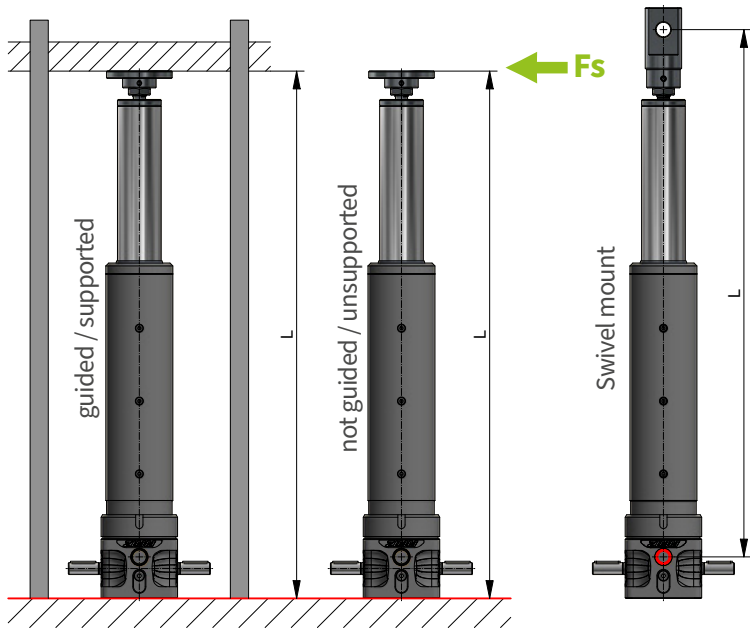

Critical buckling force ZA-25

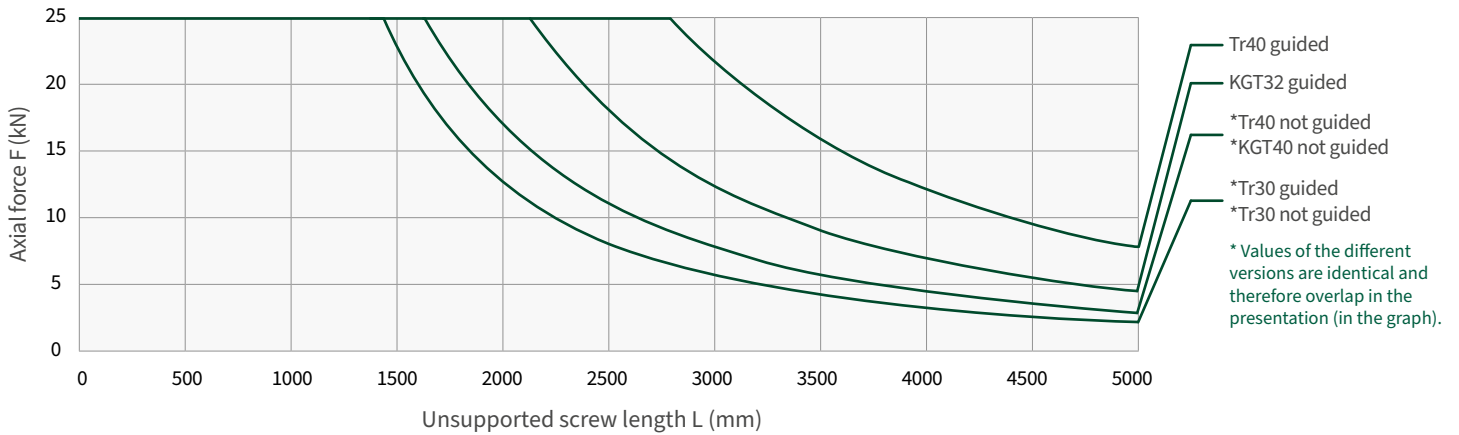

KGT load rating [kN]

	KGT32x5	KGT32x10	KGT32x20
dyn. C	24,8	30,8	32,9
stat. C ₀	49,7	45,6	47,1

Ordering example: ZA-25 1,00 Tr 30x6-RH -H800



Dynamic lateral force Fs (max.)

Fully extended L [mm]	max. Fs [N] (dynamic)	
	Standard	Heavy duty screw**
500	410	1540
600		1220
700		1000
800		850
900		740
1000		650
1200		510
1500		380
2000		260
2500		-
3000	-	

For tensile loads in conjunction with lateral forces, the permissible load is limited to 60% of the nominal load (max. tensile force ZA-25 = 15kN). Part-turn actuator excluded from this limitation.

For compressive loads, the buckling diagram must also be observed.

**Only with reinforced mounting component from size ZE-50

Technical data

max. compressive/tensile force:	25 kN (2,5 t) static
Input speed:	1500 rpm / max. 3000 rpm
Housing:	aluminium, corrosion-resistant
Push rod:	steel, chrome-plated
Worm shaft:	steel, case-hardened, ground
Weight of actuator body:	11 kg
Weight per 100 mm stroke:	2,4 kg
Cylinder tube:	steel
Gearbox lubrication:	synthetic fluid grease
Screw lubrication:	grease lubrication
Gearbox operating temp.:	max. 60°C, higher on request
IP code:	max. IP64

**see accessories from page 15

50 kN

ZA-50 | Electromechanical actuators

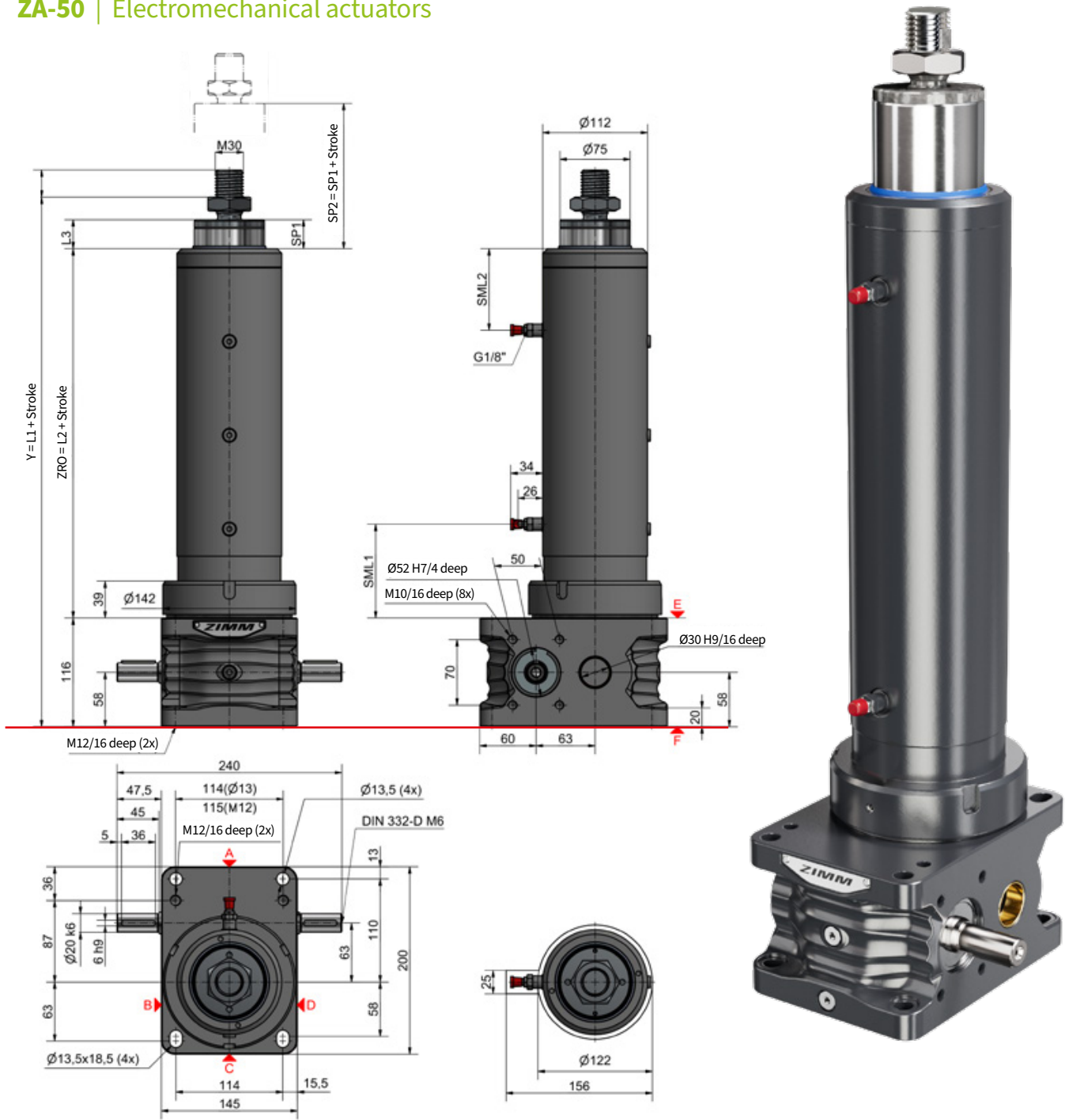

Standard configuration

Code	Ratio	Screw	Stroke per drive shaft rotation
ZA-50	28:1	Tr40x7	0,25 mm
		Tr50x8	0,29 mm
	7:1	Tr40x7	1,00 mm
		Tr50x8	1,14 mm
	28:1	KGT40x5	0,18 mm
		KGT40x10	0,36 mm
	7:1	KGT40x5	0,71 mm
		KGT40x10	1,43 mm
		KGT40x20	2,86 mm

Length calculations

	Standard TR mm	SIFA TR mm	KGT40x5 mm	KGT40x10 mm	KGT40x20 mm
L1	379	393	427	427	472
L2	216	230	259	259	289
L3	23	23	28	28	43
SP1	23	23	28	28	43
SML1	75	89	112	112	127
SML2	140	140	147	147	162

Lubrication position SP1 corresponds to standard lubrication length SML1
Safety distance L3.

For the lubrication of the screw drive and the anti-rotation lock, the lubrication positions SP1 (retracted) and SP2 (extended) must be maintained at ± 2 mm.

Technische Infos

ZA-50 | Critical buckling force & critical whirling speed

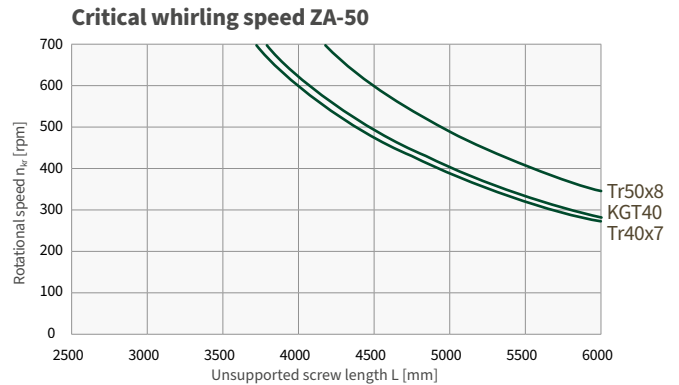
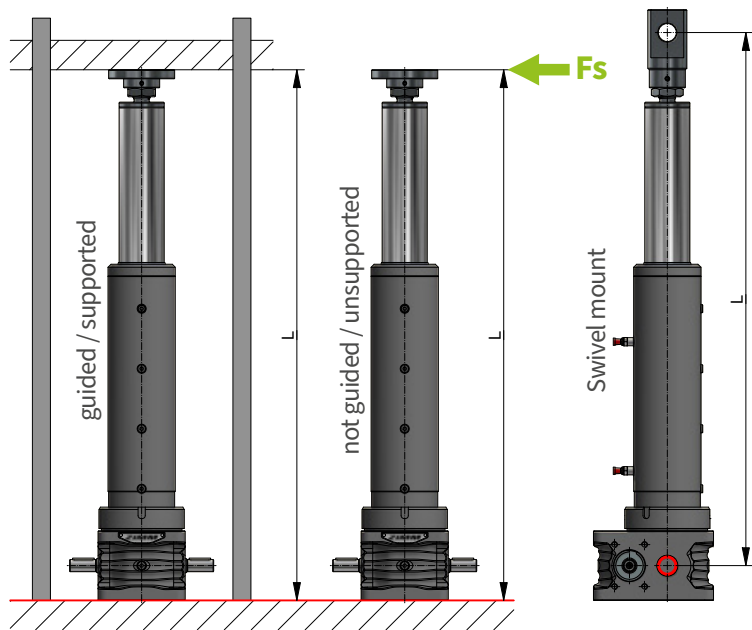

Critical buckling force ZA-50

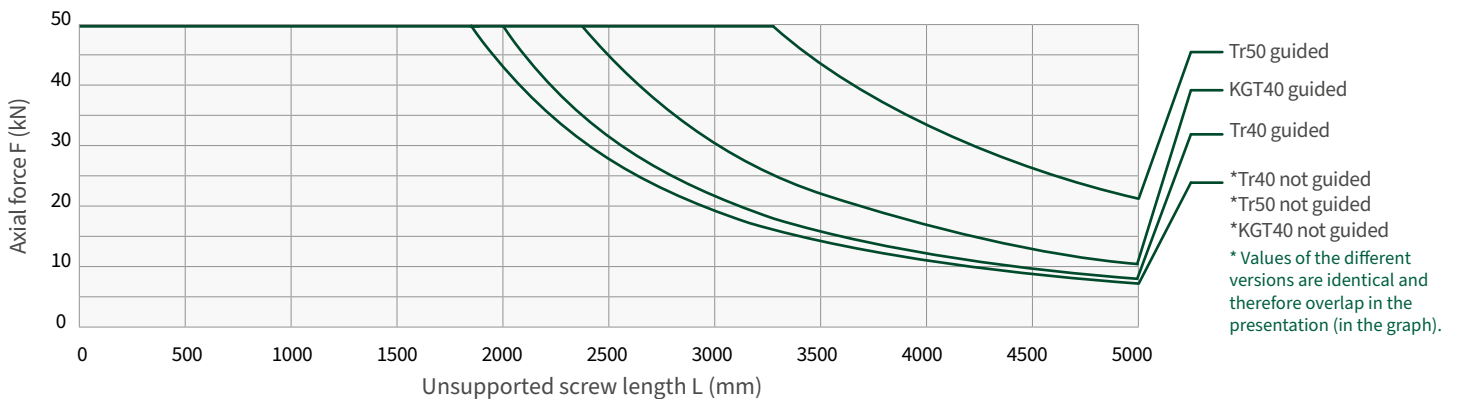

KGT load rating [kN]

	KGT40x5	KGT40x10	KGT40x20
dyn. C	27,5	46,1	44,0
stat. C ₀	63,6	71,3	80,4

Ordering example: ZA-50 1,00 Tr 40x7-RH -H800



Dynamic lateral force Fs (max.)

Fully extended L [mm]	max. Fs [N] (dynamic)	
	Standard	Heavy duty screw**
500	900	2020
600		2020
700		1800
800		1580
900		1370
1000		1200
1200	930	
1500	730	
2000	490	
2500	350	
3000	260	

For tensile loads in conjunction with lateral forces, the permissible load is limited to 60% of the nominal load (max. tensile force ZA-50 = 30kN). Part-turn actuator excluded from this limitation.

For compressive loads, the buckling diagram must also be observed.

Only with reinforced mounting component from size ZE-100

Technical data

max. compressive/tensile force:	50 kN (5 t) static
Input speed:	1500 rpm / max. 1800 rpm
Housing:	GGG, corrosion-resistant
Push rod:	steel, chrome-plated
Worm shaft:	steel, case-hardened, ground
Weight of actuator body:	31,5 kg
Weight per 100 mm stroke:	3,6 kg
Cylinder tube:	steel
Gearbox lubrication:	synthetic fluid grease
Screw lubrication:	grease lubrication
Gearbox operating temp.:	max. 60°C, higher on request
IP code:	max. IP64

**see accessories from page 15

100 kN

ZA-100 | Electromechanical actuators

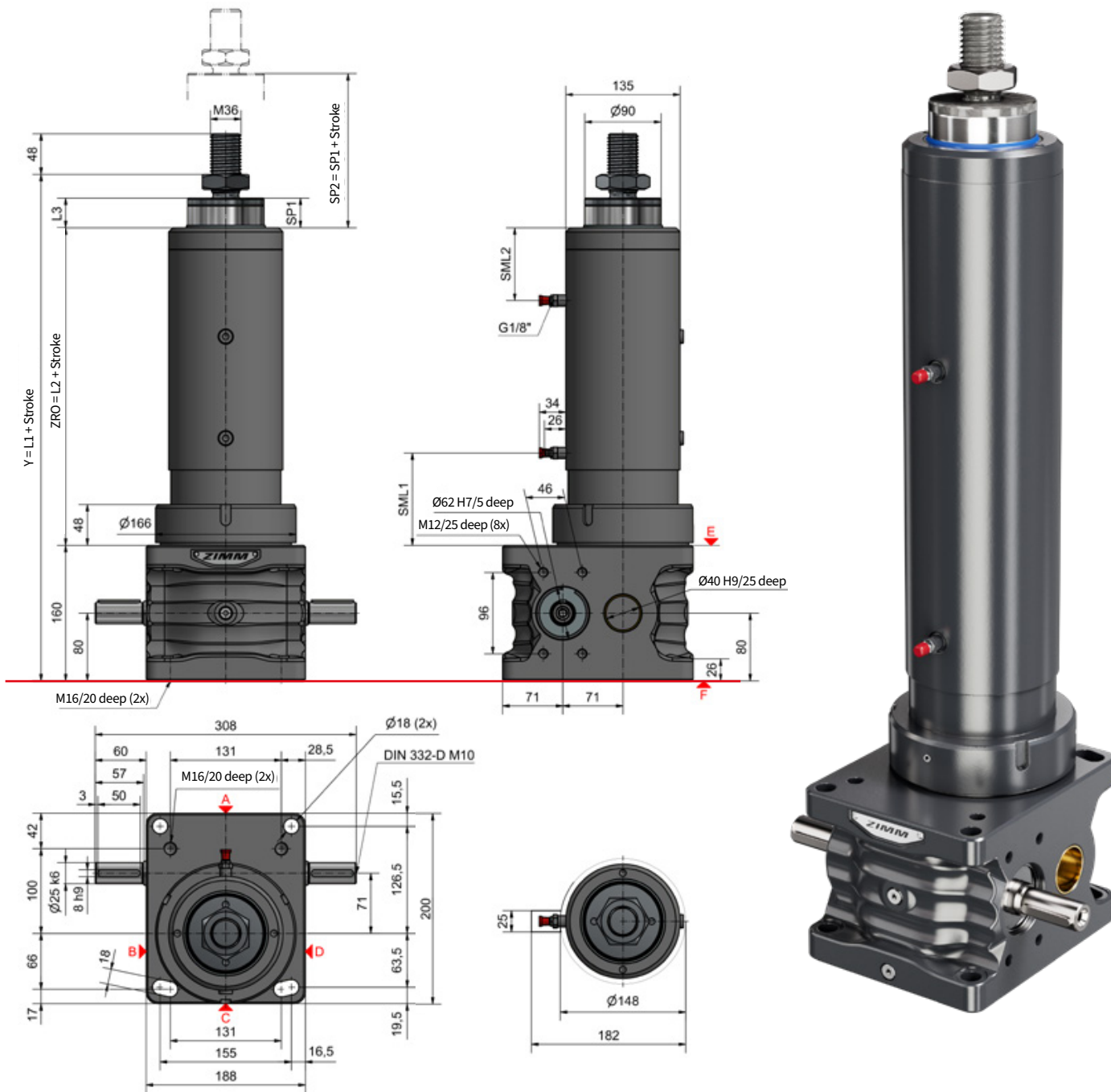

Standard configuration

Code	Ratio	Screw	Stroke per drive shaft rotation
ZA-100	36:1	Tr55x9	0,25 mm
		Tr60x9	0,25 mm
	9:1	Tr55x9	1,00 mm
		Tr60x9	1,00 mm
	36:1	KGT50x10	0,28 mm
		KGT50x20	0,56 mm
9:1	KGT50x10	1,11 mm	
	KGT50x20	2,22 mm	

Length calculations

	Standard TR	SIFA TR	KGT50x10	KGT50x20
L1	506	540		
L2	285	319		
L3	33	33		
SP1	33	33		
SML1	99	133		
SML2	186	186		

on request

Lubrication position SP1 corresponds to standard lubrication length SML1
Safety distance L3.

For the lubrication of the screw drive and the anti-rotation lock, the lubrication positions lubrication positions SP1 (retracted) and SP2 (extended) must be maintained at ± mm.

Technische Infos

ZA-100 | Critical buckling force & critical whirling speed

ON REQUEST

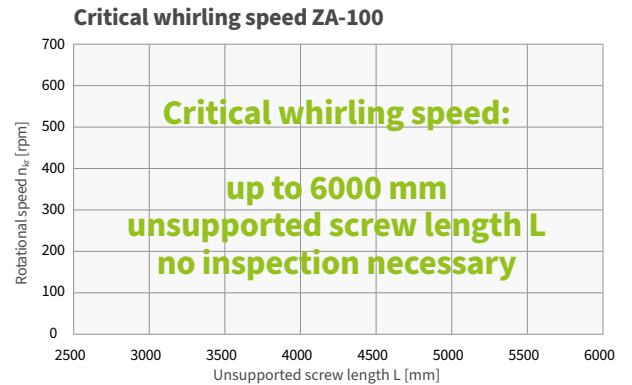
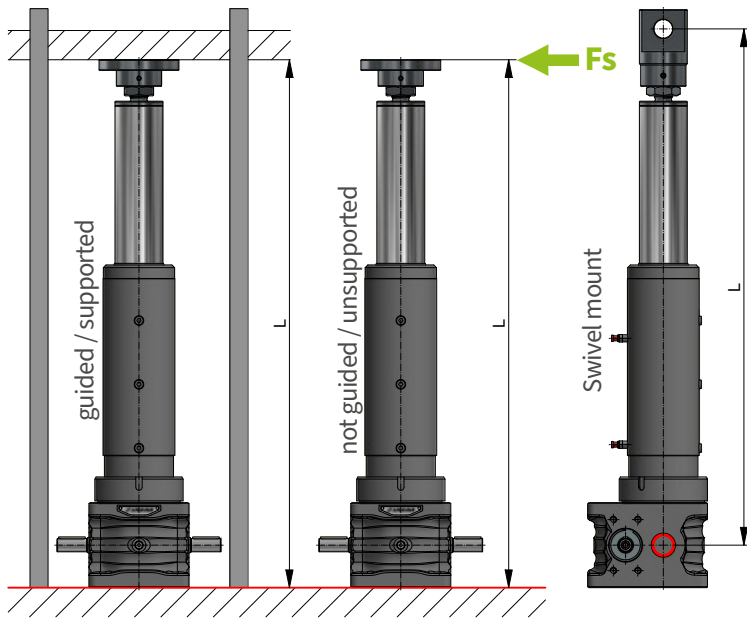

Critical buckling force ZA-100

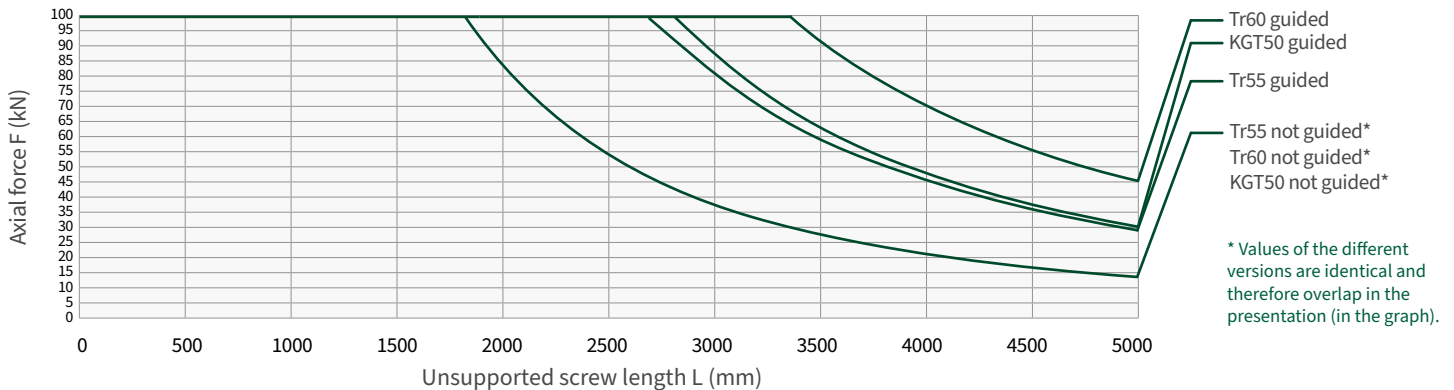

KGT load rating [kN]

	KGT50x10	KGT50x20
dyn. C	122,4	114,9
stat. C ₀	248,6	237,6

Ordering example: ZA-100 1,00 Tr 55x9-RH -H800

Size: ZA-100
 Speed: 1,00
 Thread version / variant: Tr 55x9-RH
 Stroke: 1000
 Screw diameter: 55
 Screw pitch: 9

Dynamic lateral force Fs (max.)

Fully extended L [mm]	max. Fs [N] (dynamic)	
	Standard	Heavy duty screw**
600	920	2630
700		2580
800		2220
900		1950
1000		1720
1200		1400
1500		1060
2000		740
2500	520	
3000	380	

For tensile loads in conjunction with lateral forces, the permissible load is limited to 60% of the nominal load (max. tensile force ZA-100 = 60kN). Part-turn actuator excluded from this limitation.

For compressive loads, the buckling diagram must also be observed.

Only with reinforced mounting component from size ZE-150

Technical data

- max. compressive/tensile force: 100 kN (10 t), static
- Input speed: 1500 rpm / max. 1800 rpm
- Housing: GGG, corrosion-resistant
- Push rod: steel, chrome-plated
- Worm shaft: steel, case-hardened, ground
- Weight of actuator body: 64,5 kg
- Weight per 100 mm stroke: 5,6 kg
- Cylinder tube: steel
- Gearbox lubrication: synthetic fluid grease
- Screw lubrication: grease lubrication
- Gearbox operating temp.: max. 60°C, higher on request
- IP code: max. IP64

**see accessories from page 15

200 kN

ZA-200 | Electromechanical actuators

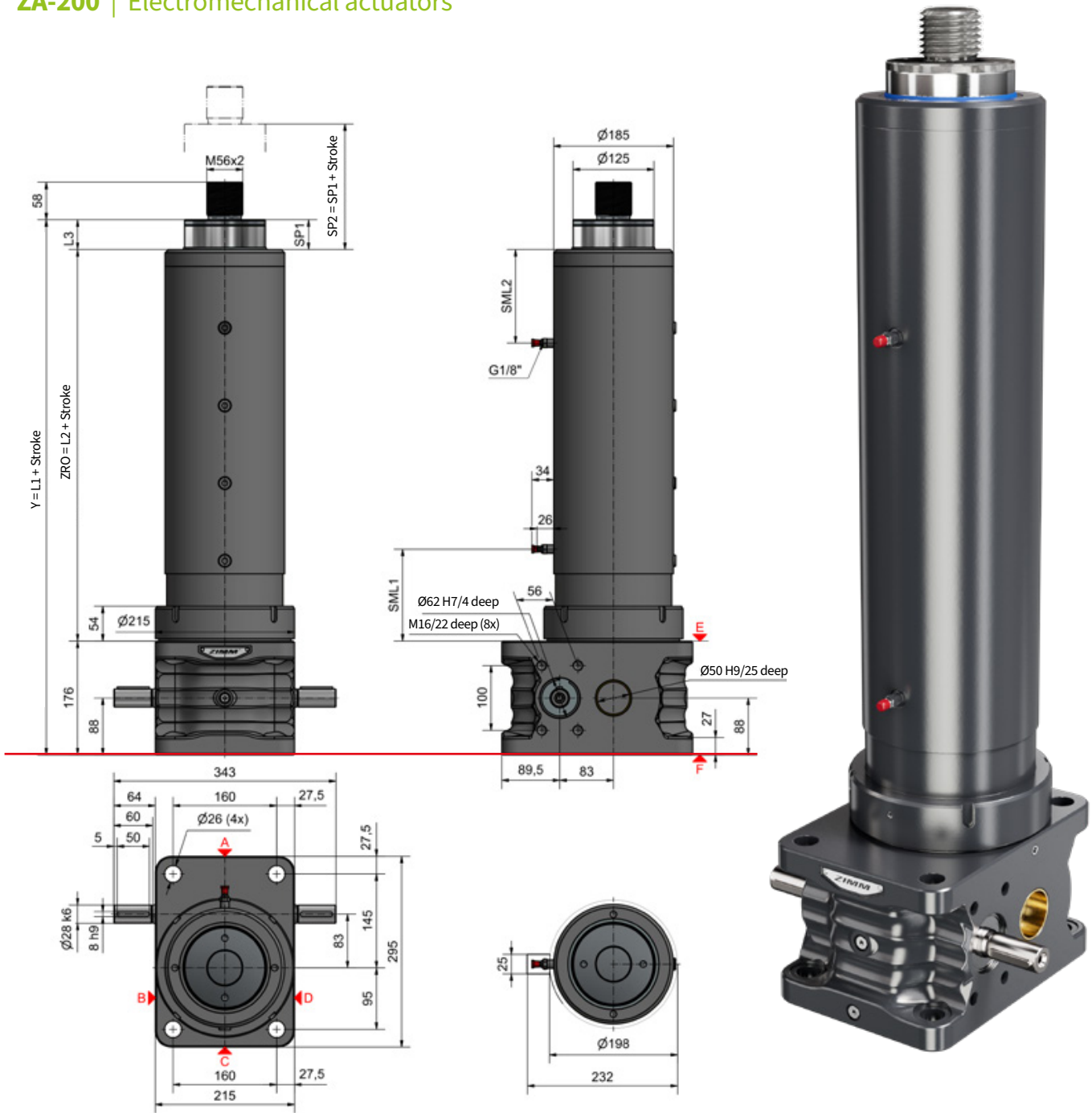

Standard configuration

Code	Ratio	Screw	Stroke per drive shaft rotation
ZA-200	24:1	Tr70x12	0,50 mm
		Tr80x16	0,67 mm
	8:1	Tr70x12	1,50 mm
		Tr80x16	2,00 mm
	24:1	KGT80x10	0,42 mm
		KGT80x20	0,83 mm
8:1	KGT80x10	1,25 mm	
	KGT80x20	2,50 mm	

Length calculations

	Standard TR	SIFA TR	"KGT50x10 mm"	"KGT50x20 mm"
L1	548	591	on request	
L2	339	382		
L3	33	33		
SP1	33	33		
SML1	114	157		
SML2	225	225		

Lubrication position SP1 corresponds to standard lubrication length SML1
Safety distance L3.

For the lubrication of the screw drive and the anti-rotation lock, the lubrication positions SP1 (retracted) and SP2 (extended) must be maintained at ± 2 mm.

Technische Infos

ZA-200 | Critical buckling force & critical whirling speed

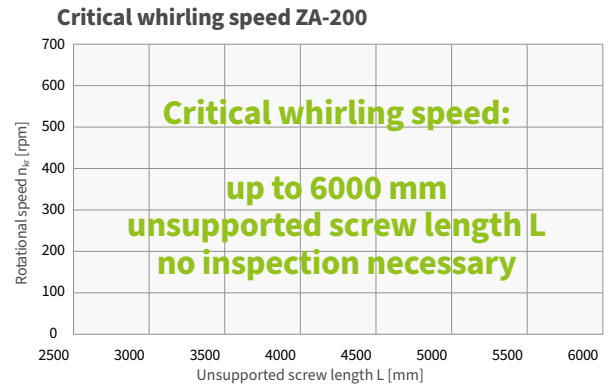
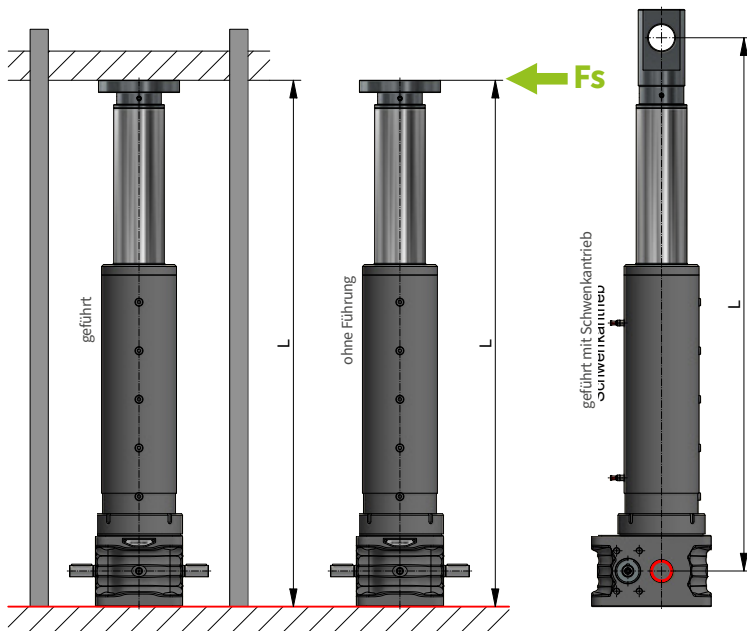

Critical buckling force ZA-200

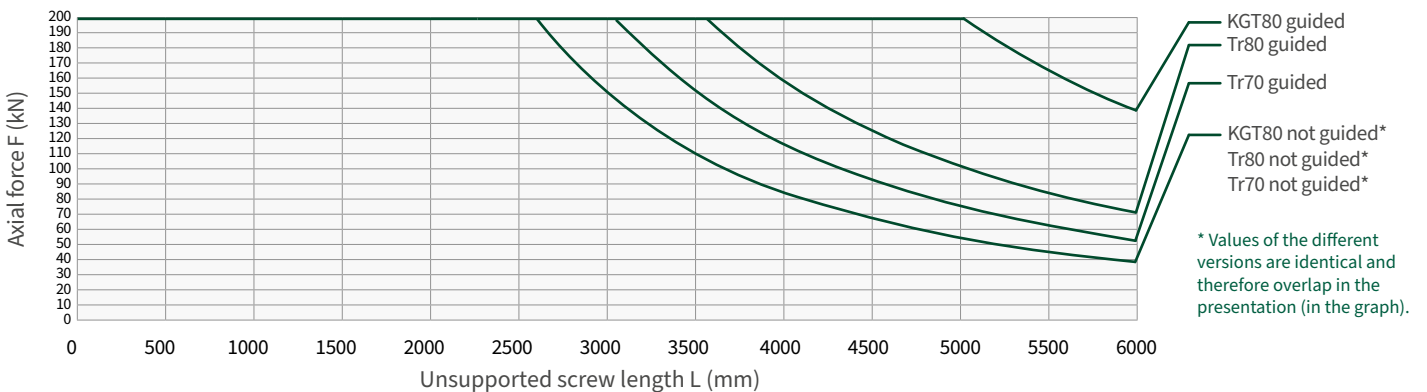

KGT load rating [kN]

	KGT80x10	KGT80x20
dyn. C	206,0	463,5
stat. C ₀	710,8	1163,7

Ordering example: ZA-200 1,50 Tr 70x12-RH -H800

Size: 1,50 Stroke: H800
 Speed: Tr Screw diameter: 70
 Thread version / variant: RH Screw pitch: 12

Dynamic lateral force Fs (max.)

Fully extended L [mm]	max. Fs [N] (dynamic)	
	Standard	
700	4720	
800	4110	
900	3600	
1000	3220	
1200	2640	
1500	2080	
200	1480	
2500	1120	
3000	860	

For tensile loads in conjunction with lateral forces, the permissible load is limited to 60% of the nominal load (max. tensile force ZA-200 = 120kN). Part-turn actuator excluded from this limitation.

For compressive loads, the buckling diagram must also be observed.

Technical data

- max. compressive/tensile force: 200 kN (20 t), static
- Input speed: 1500 rpm / max. 1800 rpm
- Housing: GGG, corrosion-resistant
- Push rod: steel, chrome-plated
- Worm shaft: steel, case-hardened, ground
- Weight of actuator body: 112 kg
- Weight per 100 mm stroke: 11 kg
- Cylinder tube: steel
- Gearbox lubrication: synthetic fluid grease
- Screw lubrication: grease lubrication
- Gearbox operating temp.: max. 60°C, higher on request
- IP code: max. IP64

Faster and easier to the complete lifting system

ZIMM modular system

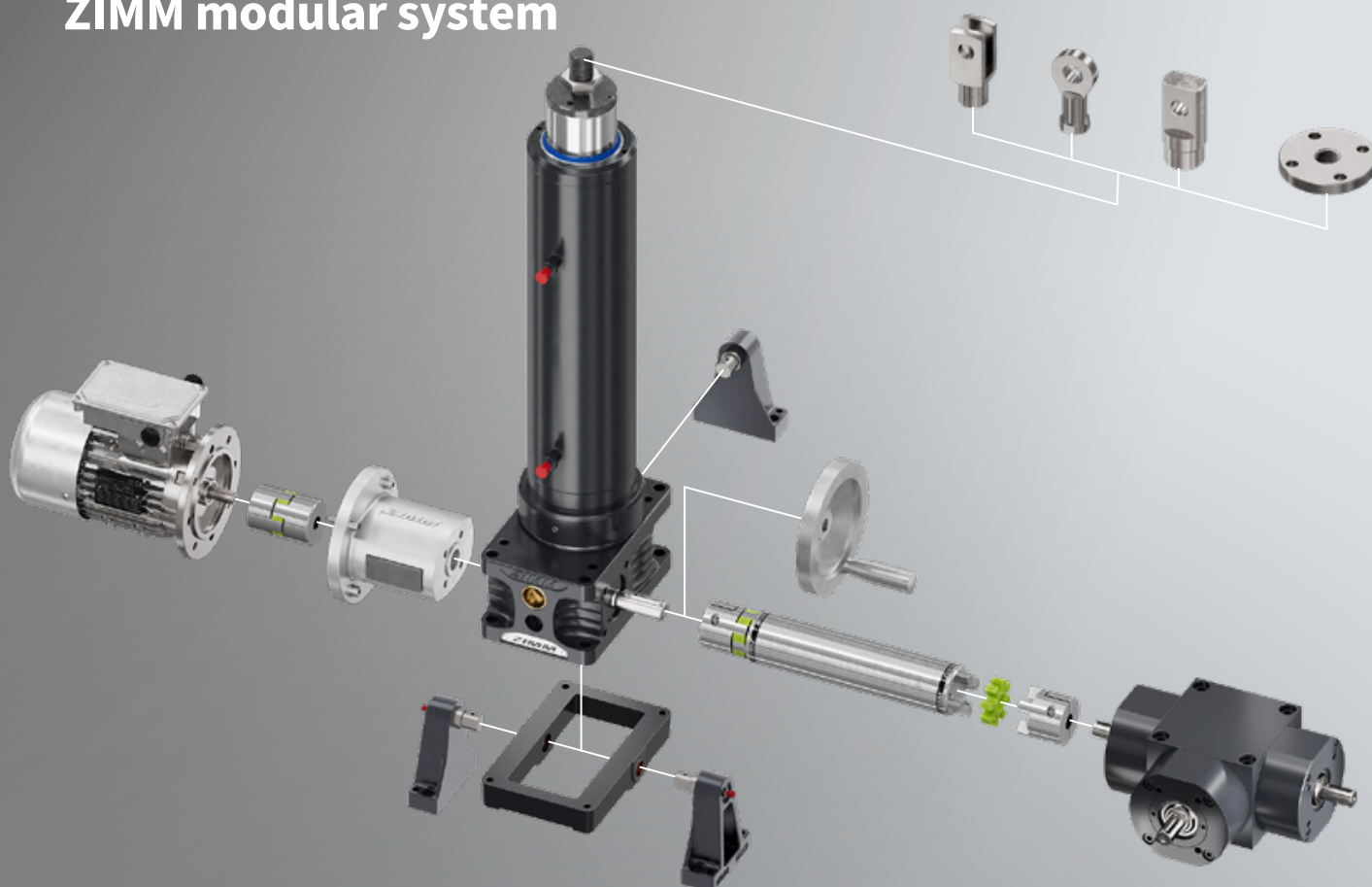

At ZIMM, speed, know-how and customer friendliness have a system.

The more comprehensive ZIMM modular system is harmonised with all ZIMM gearbox series. This means that the same mounting parts for the ZIMM actuators fit the screw jacks and bevel gearboxes.

Accessoires

Fixing flange & Connections	15
Pivoting.....	16 - 17
Handwheel & Protective cap.....	18
Motor flange	19
Three-phase AC motors.....	20 - 25
Connecting shafts	26 - 27
Pedestal bearing.....	28 - 29
Couplings	
Standard coupling.....	30 - 31
Clamp coupling.....	32 - 33
Bevel gearboxes	34 - 35
Motor flange combinations	37

Accessories

Add-on components | Fixing flange & connections

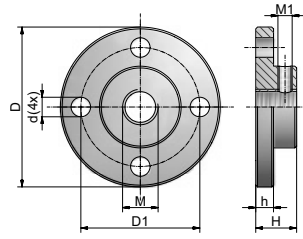

Fixing flange BF

Code	D	D1	D2	M	d	h	H	M1	kg
ZE-25-BF	90	67	46	M20	11	10	23	8	0,5
ZE-50-BF	110	85	60	M30	13	15	30	8	1,2
ZE-100-BF	150	117	85	M36	17	20	50	10	3,5
ZE-150-BF	170	130	90	M42x2	21	25	50	10	4,7
ZE-200-BF	200	155	110	M56x2	26	30	60	12	7,8

Material: steel, corrosion-resistant ; aluminum

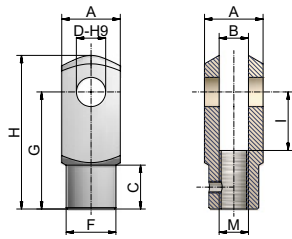

Forked end GK

Code	A	B	C	D	M	F	G	H	I	kg
ZE-25-GK	40	20	30	20	M20	34	80	105	40	0,7
ZE-50-GK	60	30	42	30	M30	52	120	160	60	2,5
ZE-100-GK	70	36	54	35	M36	60	144	188	72	3,7
ZE-150-GK	85	42	63	42	M42x2	70	168	232	84	5,3

Material: steel, galvanised (INOX on request) incl. bolt, splint and set screw

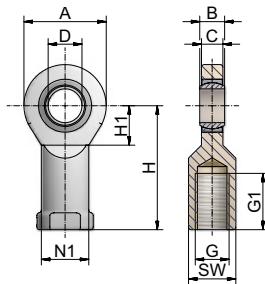

Rod end KGK

Code	A	B	C	D	G	G1	H	H1	SW	N1	kg
ZE-25-KGK	53	16	13	20	M20	40	77	27,5	30	27,5	0,32
ZE-50-KGK	73	22	19	30	M30	56	110	37	46	40	1,03
ZE-100-KGK	92	28	24	40	M36	65	142	46	60	52	2,1
ZE-150-KGK	112	35	31	50	M42x2	68	160	56	70	62	3,61
ZE-200-KGK	135	44	38	60	M56x2	70	175	73	75	70	5,6

Material: steel/steel, galvanised

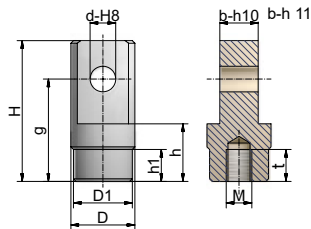

Pivot bearing end SLK

Code	H	D	D1	d	M	g	b	h	h1	t	kg
ZE-25-SLK	110	50	46	20	M20	80	30	45	25	25	1,2
ZE-50-SLK	130	65	60	30	M30	92	35	50	30	33	2,1
ZE-100-SLK	144	90	85	35	M36	108	40	65	40	55	4,4
ZE-150-SLK	210	100	90	50	M42x2	155	57	90	50	70	8
ZE-200-SLK	235	115	110	65	M56x2	165	70	85	45	63	12

Material: steel, corrosion resistant incl. set screw

The entire ZIMM product range can be easily viewed in detail on our website. can be accessed via our website. Whether on your PC or smartphone, click through all products including attachments and accessories. It is also possible to upload your enquiry – including a drawing if required – directly and send it digitally to our sales team.



Accessories

Add-on components | Pivoting



Pivot mount LB (25 kN)

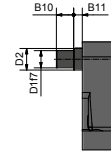
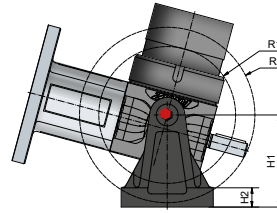
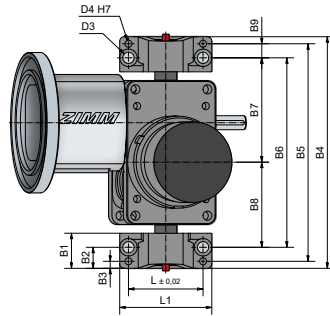

Axis of pivoting **R**
(at right angles to the drive)

Code	B1	B2	B3	B4	B5	B6	B7	B8	B9	B10	B11	D1	D2	D3	D4	H1	H2	L1	L2	R1	R2	kg/Set
ZE-25 (25-LB)	40	24	8	264	248	216	119	97	16	20	10	20	25	13	8	105	21	105	85	78	100	1,3

Ordering example

ZE-25-LB Set (2 items)

Lubrication

The bronze bushes are PTFE-coated and therefore require no lubrication in normal service. We recommend regular lubrication for high loadings.

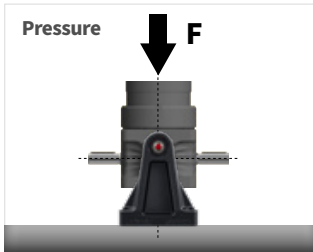

Permissible nominal load 19,5 kN

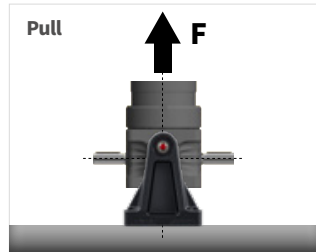

Permissible nominal load 17,5 kN

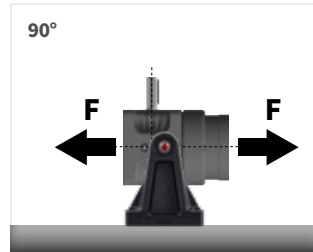

Permissible nominal load 10 kN

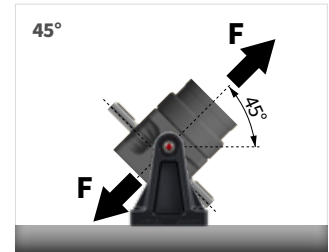

Permissible nominal load 9,5 kN



Pivot mount LB (50 - 200 kN)

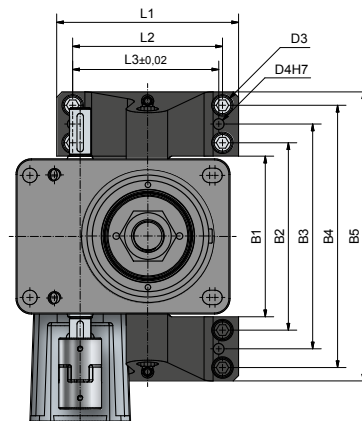
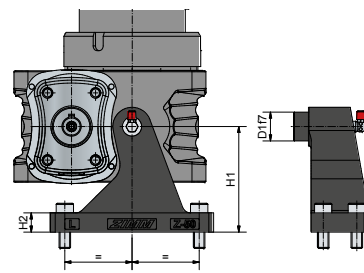

Axis of pivoting **P**
(parallel to the drive)

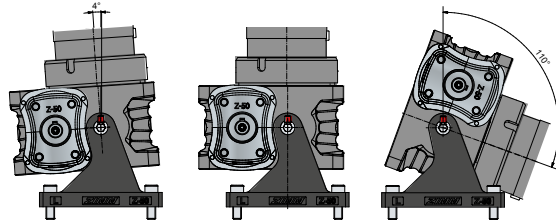

Note

From size 50, pivot bushes can be subjected to the full nominal load in tension. Exception: size 200 from 90° to 45° (see table).

Code	D1	D3	D4	H1	H2	L1	L2	L3	B1	B2	B3	B4	B5	kg/Set	Permissible nominal load		
															Pressure	Pull	90° & 45°
ZE-50-LB	30	13	10	110	18	170	140	140	150	175	210	245	270	5	50 kN	50 kN	50 kN
ZE-100-LB	40	22	20	120	22	260	180	225	210	250	290	330	370	11,8	100 kN	100 kN	100 kN
ZE-200-LB*	50	22	20	135	24	280	200	235	237	277	327	377	417	18	150 kN	150 kN	150 kN

Material: cast steel, tempered, corrosion-resistant

*ZE-150-LB is used for the ZE-200-LB. Max. load capacity: 150 kN

Integrated pivot bearing

Pivot bushes are integrated in the gearbox housing as standard.

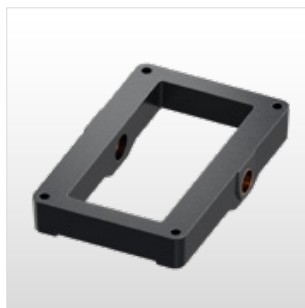
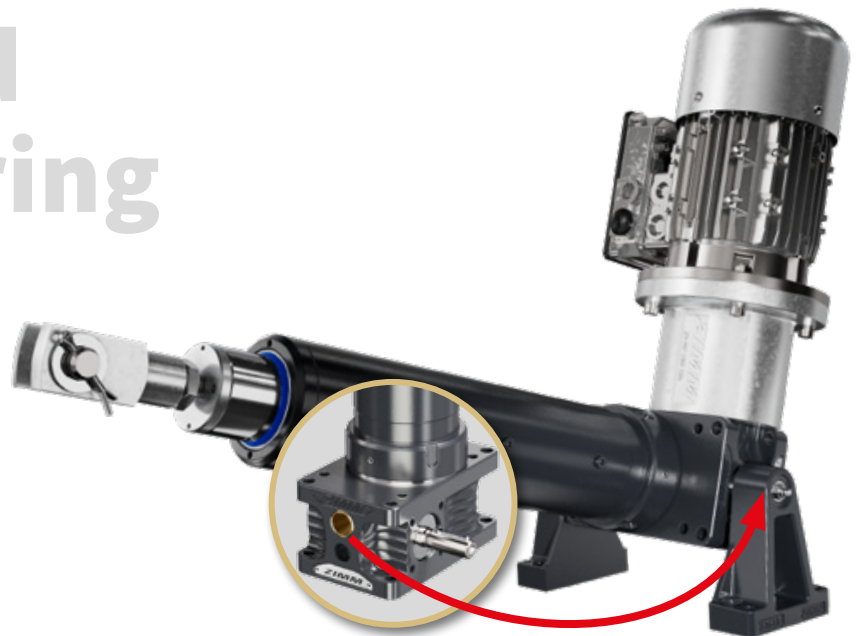

Pivot bearing plate KAR (25 kN)

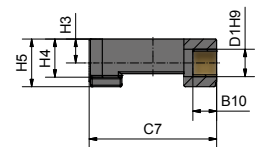
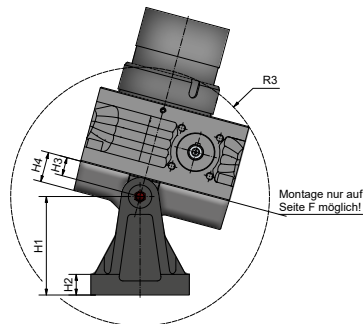
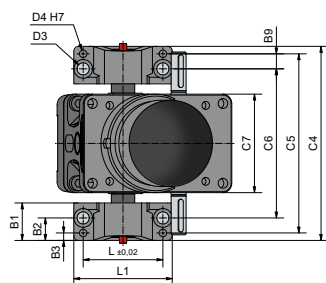

Axis of pivoting **P**
 (Parallel to the drive))

For large motors, long strokes and a high operating cycle, the variant with the slide bearing plate KAR is to be preferred because then the motor weight is absorbed by the pivot bearing plate and does not affect the spindle.

Code	B1	B2	B3	B9	B10	C4	C5	C6	C7	D1	D3	D4	H1	H2	H3	H4	H5	L1	L2	R3	kg
ZE-25-KAR	40	24	8	16	20	207	191	159	107	20	13	8	105	21	20	32	40	105	85	138	0,8

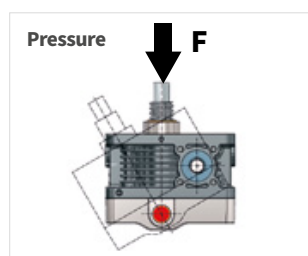

Permissible nominal load 25 kN

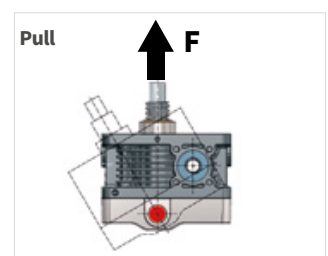

Permissible nominal load 10 kN



Note
 The KAR pivot bearing plate allows several 25 kN jacks to be arranged in a row.

Accessories

Add-on components | Handwheel & Protective cap



Handwheel HR

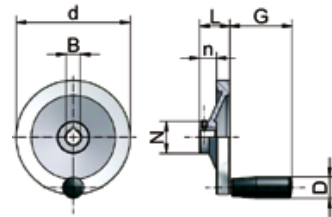

Code	d	N	b	n	L	G	D	B H7 pilot hole	B H7 with nut	kg
HR-125	125	31	15	18	33	67,5	23	6	16	0,3
HR-160	160	36	18	20	39	82,5	26	6	16/20	0,5
HR-200	200	42	20,5	24	45	82,5	26	16	16/20	1
HR-250	250	48	23	28	51	92,5	28	22	20/25/28	1,3

Material: Aluminium, plastic (handle)

Design: No more than max. 50 - 60 N force should be required at the handle.

Other diameters on request.



Protective cap SK

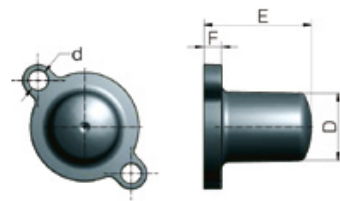

Code	D	d	E	F	Screws DIN 912	kg
ZE-25-SK	31	9	49	8	M8x16	0,05
ZE-50-SK	35	11	55	8	M10x20	0,08
ZE-100/150-SK	46	13,5	74	8	M12x25	0,13
ZE-200-SK	60	17,5	82	25	M16x25	0,50

Incl. screws

Material: ZE-5 to ZE-200: PA6 GF15, up to 120°C, briefly 180°C.

Material: Z-250 to Z-1000: POM, up to 100°C, briefly 140°C.

incl. screws

ZA-25 to ZA-150
KSZ-H-5 to KSZ-H-150

Suitable for all ZIMM gearboxes (ZA, ZE, Z, GSZ and KSZ-H bevel gearboxes).

CAUTION

For bevel gearboxes, the protective cap must be the same size as the motor flange.

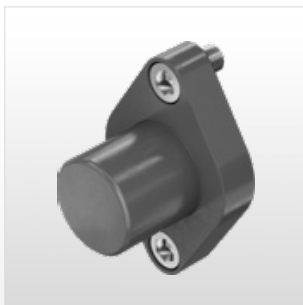

ZE-200-SK

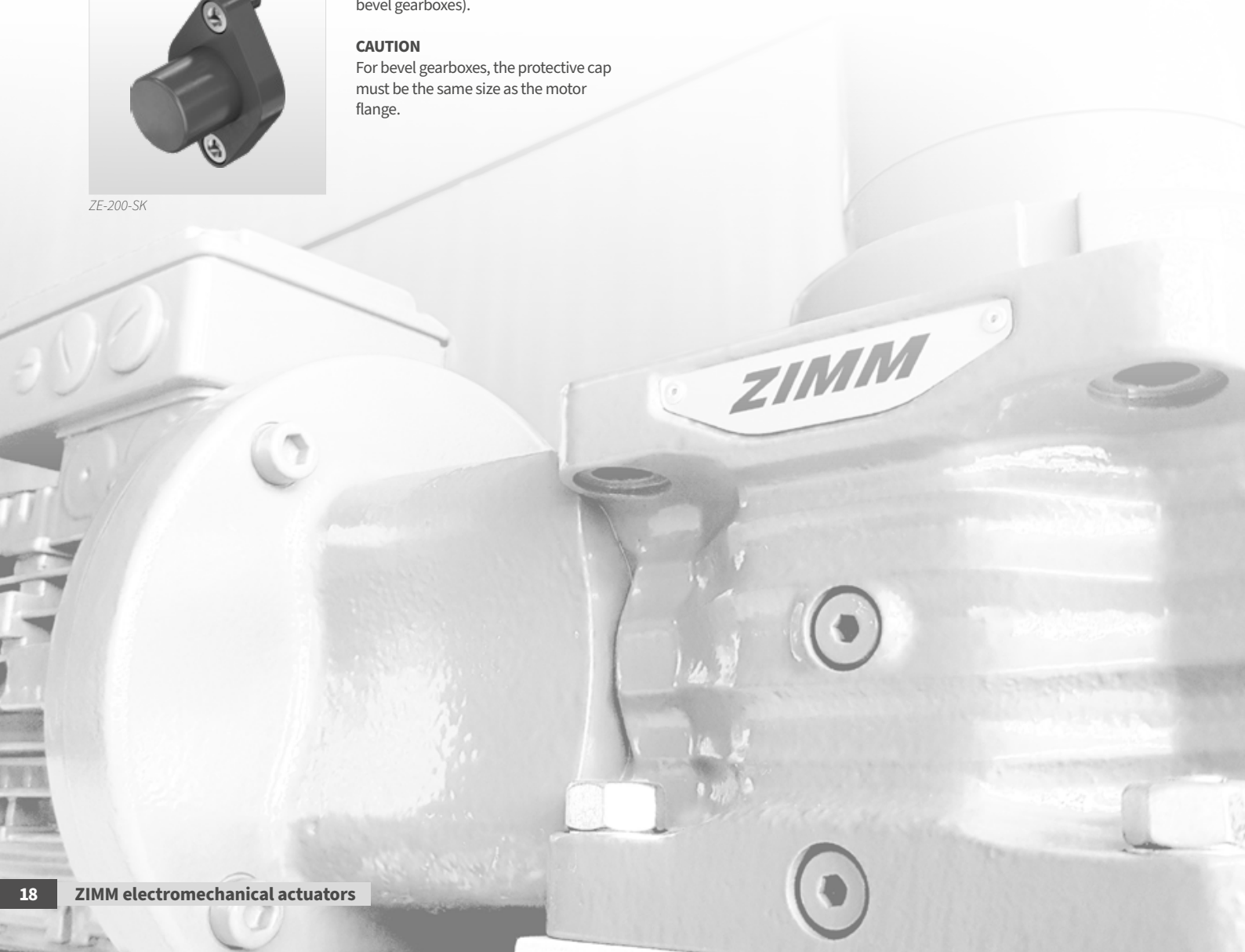

Accessories

Add-on components | Motor flange

Motor flange MF 25 kN

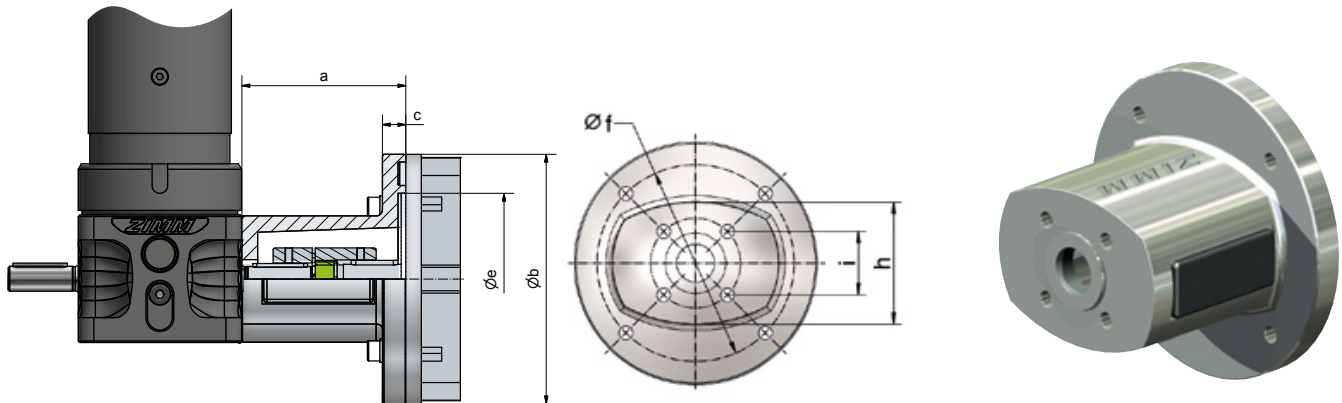

Code	Motor Type	Coupling Code Bore - ϕ			2 screws gearbox side 8.8	4 screws motor side 8.8 DIN 912 for motor	a	b	c	e	f	h	i	kg
		Size	Gearbox	Motor										
ZE-25-MF-160-105	71 B5	KUZ-28	16	14	M8x20 - DIN 7991	M8x35 + nuts	105	160	15	110	130	81	42	1,1
ZE-25-MF-160-105	80 B14B	KUZ-24	16	19	M8x20 - DIN 7991	M8x30 + spring washers	105	160	15	110	130	81	42	1,1
ZE-25-MF-160-105	90 B14B	KUZ-24	16	24	M8x20 - DIN 7991	M8x30 + spring washers	105	160	15	110	130	81	42	1,1
ZE-25-MF-160-122	100 B14C	KUZ-28	16	28	M8x20 - DIN 7991	M8x30 + spring washers	122	160	15	110	130	81	42	1,2

Material: aluminium, all screws galvanised DIN 934 nut and DIN 128 spring washer, supplied incl. screws

Motor flange base MF-B and motor flange plate MF-P - ZE-50 to ZE-200

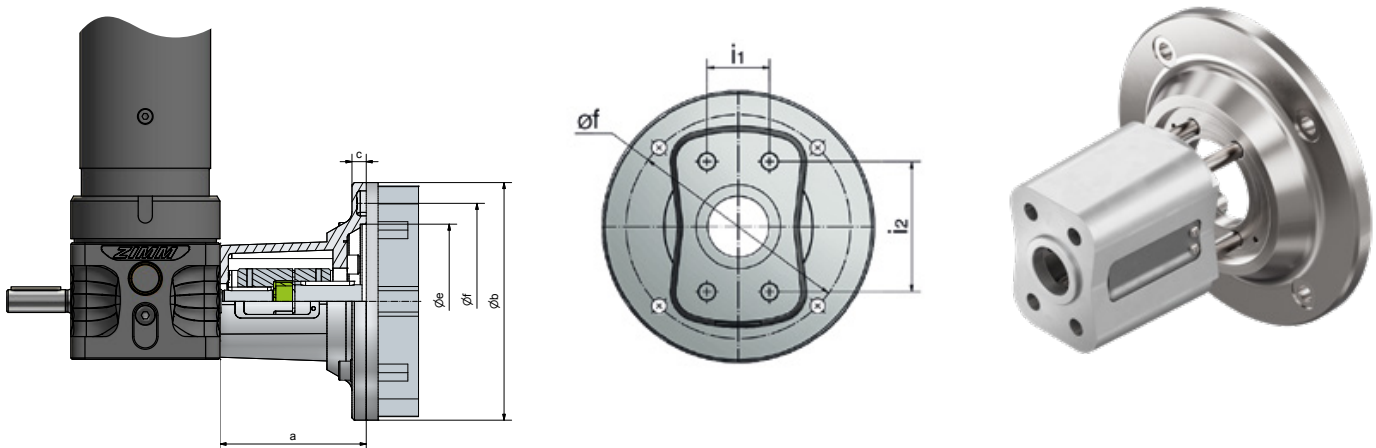

Code	Motor Type	Coupling code Bore - ϕ			4 screws gearbox side DIN 912	4 screws motor side DIN 912	a	b	c	e	f	i1	i2	kg
		Size	Gearbox	Motor										
ZE-50-MF-200-116	90 B5	KUZ-28	20	24	M10x30	M10x45 ²⁾	116	200	20	130	165	50	70	4,1
ZE-50-MF-200-126	100 B14B	KUZ-28	20	28	M10x30	M10x35 ¹⁾	126	200	20	130	165	50	70	4,3
ZE-50-MF-200-126	112 B14B	KUZ-28	20	28	M10x30	M10x35 ¹⁾	126	200	20	130	165	50	70	4,3
ZE-50-MF-B + special plate	Servomotors, geared motors, Nema, ...													
ZE-100/150-MF-200-138	100 B14B	KUZ-28	25	28	M12x40 ⁴⁾	M10x35 ¹⁾	138 ³⁾	200	20	130	165	46	96	5,3
ZE-100/150-MF-200-138	112 B14B	KUZ-28	25	28	M12x40 ⁴⁾	M10x35 ¹⁾	138 ³⁾	200	20	130	165	46	96	5,3
ZE-100/150-MF-B + P-200	132 B14C	KUZ-38	25	38	M12x150 ⁴⁾	M10x65 ¹⁾	161 ³⁾	200	48	130	165	46	96	8,7
ZE-100/150-MF-B + special plate	Servomotors, geared motors, Nema, ...													
ZE-200-MF-200-168	100 B14B	KUZ-38	28	28L	M16x45	M10x40 ¹⁾	168	200	20	130	165	56	100	8,1
ZE-200-MF-200-168	112 B14B	KUZ-38	28	28L	M16x45	M10x40 ¹⁾	168	200	20	130	165	56	100	8,1
ZE-200-MF-200-168	132 B14C	KUZ-38	28	38	M16x45	M10x40 ¹⁾	168	200	20	130	165	56	100	8,1
ZE-200-MF-200-168 + P-350	160 B5	KUZ-45	28A	42	M16x45	M16x70 ²⁾	198	350	30	250	300	56	100	24,8
ZE-200-MF-200-168 + special plate	Servomotors, geared motors, Nema, ...													

Material: GGG-50, korrosionssgeschützt, alle Schrauben verzinkt Mutter DIN 934 und Federring DIN 128, Lieferung inkl. Schrauben.

1) incl. spring washers

2) incl. nuts and spring washers

3) for GSZ-100: +6.5mm (plate)

4) for GSZ-100: M12x45/M12x160

Three-phase AC motors

Overview | 0,37 kW - 15 kW

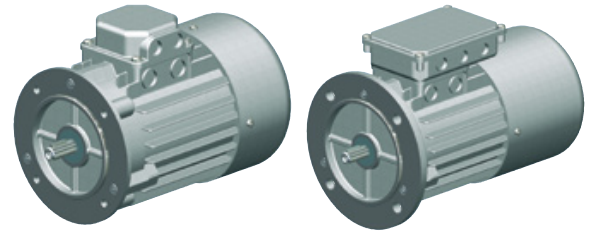

Technical data

Standard three-phase motors (asynchronous)
 No-load speed ~1500 rpm (other speeds on request)
 230/400 V Δ 50 Hz, S1 or S3-75%, ISO F
 Three-phase AC motors: IP 55
 Three-phase AC motors with brakes: IP 54

Voltage ranges:

220 - 240 V Δ 50 Hz 380 - 415 V Y 50 Hz
 380 - 415 V Δ 50 Hz 660 - 690 V Y 50 Hz

Size	Power P	Rated speed	Rated torque	Rated current at 400 V	for direct-on-line starting		Breakdown torque to rated torque	Moment of inertia J	Efficiency (at 100% load)	Power factor (at 100% load)	Weight without brake	Weight with brake
					Starting current to rated current	Starting torque to rated torque						
IEC	kW	rpm	Nm	A	I_s/I_N	M_s/M_N	M_k/M_N	approx. kgm ²	η %	cos	approx. kg	approx. kg
71	0,37	1360	2,6	1,2	2,8	2	2	0,0008	63	0,7	6	8
71	0,75*	1370	5,33	2,1	2,9	2,1	2,4	0,0012	69	0,78	8,3	10,3
80	0,75	1410	5,1	2	4,5	2,2	2,8	0,0020	70	0,7	9,3	13
80	1,5*	1390	10,4	3,4	4,1	3,2	3,2	0,0026	72	0,7	11,5	15,2
90L	1,5	1410	10,3	3,7	4,9	3	3	0,0032	79	0,74	14,4	18
90L	2,2*	1400	15,2	5,2	4,5	2,7	2,7	0,0039	78	0,81	17,5	21,1
100L	2,2	1420	14,8	5,3	4	2,3	2,7	0,0046	83	0,74	19,2	25,5
100L	3	1410	20,3	6,7	3,9	2,3	2,5	0,0056	82	0,79	22,4	28
100L	4*	1420	27	8,9	4	2,2	2,2	0,0065	81	0,82	26,3	31,9
112M	4	1440	27	9,4	3,3	2,5	2,9	0,0133	83	0,75	30,4	38
112M	5,5*	1440	36,4	11,7	3,9	2,1	2,3	0,0139	84	0,83	33	40,6
132S	5,5	1440	36	12	5,8	3	3	0,224	83	0,8	41,9	56
132M	7,5	1440	50	15,4	6,8	3,1	3,1	0,0293	86	0,82	51	66
132M	11*	1445	73,1	24,5	8,2	3,5	3,5	0,0458	83	0,8	74	89
» 160M	11	1460	72,1	20,7	7,6	2,1	2,4	0,0832	89,1	0,86	101	111
» 160L	15	1460	96,2	29,2	7,1	2,4	2,6	0,1506	89,4	0,83	110	120

Size 71 to 132 available on short lead times
 *Power is higher than the IEC-Norm (progressive)
 » Size 160 to 355 available on request

CAUTION

Overdimensioning the motor power risks overstressing other components. The effects must be considered not only under load but also for the no-load case.

We supply **motor brakes** as standard for a connection voltage of 230V AC, operating voltage 205 V DC, with bridge rectifiers.

Ordering example:

90-P4-1,5-B5-B-2W

Size _____
 Number of poles - speed 4-polig = 1500 min⁻¹ _____
 Power [kW] _____
 Design _____
 with brake (if required) _____
 with a second shaft end (if required) _____

Three-phase AC motors

General information

Connection arrangement

The motors usually have a terminal board with 6 terminals and a protective earth terminal in the terminal box. The stator winding can be switched into star or delta connection using the connection links.

Star/delta starting is not suitable for screw jack systems because full torque is required immediately on starting.

For motor windings 230/400V (example):

Δ - Connection

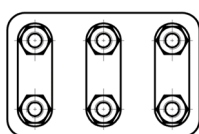

3~ 230V

Y - Connection

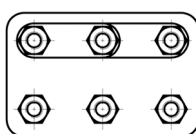

3~ 400V

Operating voltage 230V delta:

Motor windings 230/400V

Operating voltage 400V delta:

Motor windings 400/660V

Direction of rotating

Motors can be arranged for either direction of rotation. When the line phases L1, L2, L3 are connected to the motor terminals U1, V1, W1, the direction of rotation is clockwise. Swapping over two of the supply lines reverses the direction of rotation.

Speeds

Three-phase AC motors have different rotational speeds depending on the number of poles. Generally we recommend our standard motor with 1500 rpm (4 poles). Other numbers of poles are available on request. Pole-changing motors allow a choice of 2 different rotational speeds.

Speed (50 Hz)	Number of poles
3000	2
1500	4 (= preferred type)
1000	6
750	8
500	12

Geared motors

Geared motors are available for particular projects on request.

Operation with frequency converters

Especially for larger screw jacks and systems, we recommend the use of a frequency converter to achieve smooth start-up and brake ramps. This minimizes start-up noise and extends the service life of the gearbox.

When operating with a frequency converter, remember that if the motor is to be operated for extended periods at frequencies less than 25 Hz, its fan must be driven separately. This is necessary to ensure adequate motor cooling. When operating a braked motor with a frequency converter, a separate actuation line for the brake must be provided via the frequency converter.

Braked motors

We recommend using a braked motor to minimise the overrun time of the system. Where a screw jack is fitted with a ball screw or a double-pitch screw, a braked motor is absolutely essential. We supply motor brakes as standard for a connection voltage of 230V AC / operating voltage 205V DC, with bridge rectifiers. Other connection voltages (24V DC, 400V AC, 500V AC) are available on request.

Temperature monitoring

Generally we do not supply temperature monitoring because screw jack duty cycles are normally quite low or the motor is adequately dimensioned. Most standard motors above 1.5 kW are equipped with PTC. Versions with bimetal switch (TH), Temperature control thermal resistor PTC (TF) and combined are available on request.

Some types are available ex stock with thermal resistor (PTC).

Three-phase AC motors with brakes

Flange profile B14B, large flange

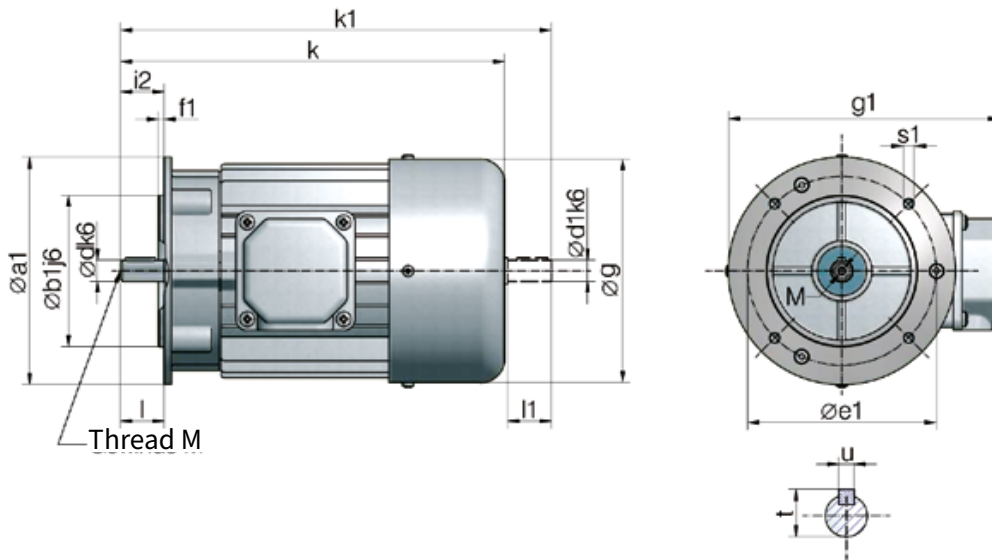

B14: Flange with internal thread
B: Large flange

Size	a1	b1	e1	f1	g	i2	s1	d	l	t	u
71	140	95	115	3	141	30	M8	14	30	16	5
80	160	110	130	3,5	159	40	M8	19	40	21,5	6
90	160	110	130	3,5	179	50	M8	24	50	27,5	8
100	200	130	165	3,5	199	60	M10	28	60	31	8
112	200	130	165	3,5	223	60	M10	28	60	31	8

These dimensions are standardised and therefore always the same

Size	kW		without brake			with brake		with brake and second shaft end			g1	M
	(4-pole)	k	k1	d1	l1	k	k1	d1	l1			
71	0,37	248	281	14	30	263	295	325	11	23	188	5
71	0,75	248	281	14	30	263	295	325	11	23	188	5
80	0,75	277	315	19	40	305	330	375	19	40	211	6
80	1,5	277	315	19	40	305	330	375	19	40	211	6
90	1,5	329	378	24	50	390	390	432	19	40	227	8
90	2,2	329	378	24	50	348	390	432	19	40	227	8
100	3	369	429	28	60	433	433	487	24	50	248	10
100	4	369	429	28	60	433	433	487	24	50	248	10
112	5,5	391	448	28	60	456	456	511	24	50	266	10

These dimensions are our standard (4-pole), but can be changed in individual cases

We reserve the right to change the dimensions, without changing the designation of the motor.

Three-phase AC motors with brakes

Flange profile B14C, small flange

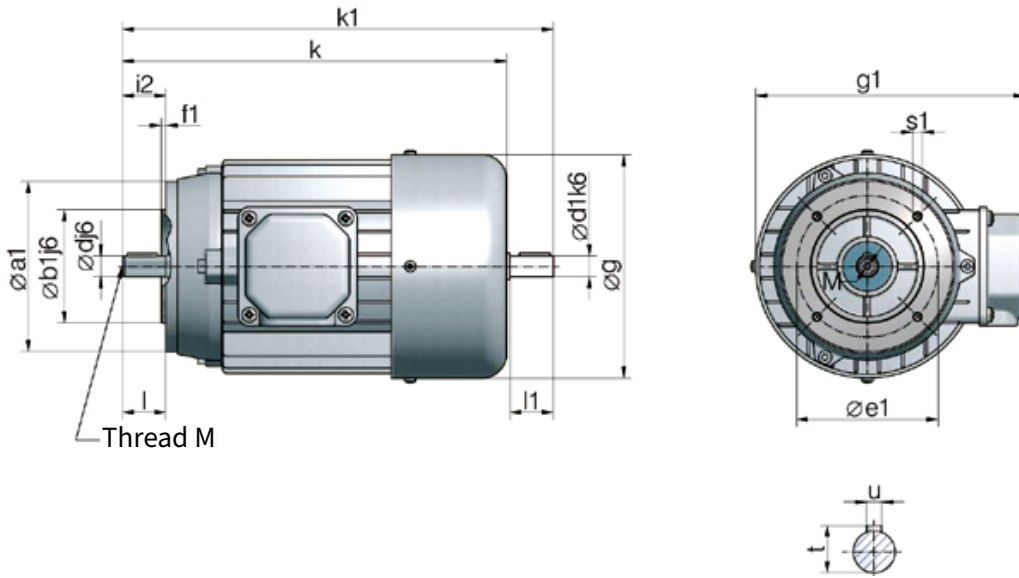

B14: Flange with internal thread
C: Small flange

Size	a1	b1	e1	f1	g	i2	s1	d	l	t	u
71	105	70	85	2,5	141	30	M6	14	30	16	5
80	120	80	100	3	159	40	M6	19	40	21,5	6
90	140	95	115	3	179	50	M8	24	50	27	8
100	160	110	130	3,5	199	60	M8	28	60	31	8
112	Dimensions on request										
132	Dimensions on request										

These dimensions are standardised and therefore always the same

Size	kW (4-pole)	without brake					with brake		with brake and second shaft end			g1	M
		k	k1	d1	l1	k	k	k1	d1	l1			
71	0,37	248	281	14	30	263	295	325	11	23	188	5	
71	0,75	248	281	14	30	263	295	325	11	23	188	5	
80	0,75	277	315	19	40	305	330	375	19	40	211	6	
80	1,5	277	315	19	40	305	330	375	19	40	211	6	
90	1,5	329	378	24	50	390	390	432	19	40	227	8	
90	2,2	329	378	24	50	348	390	432	19	40	227	8	
100	3	369	429	28	60	433	433	487	24	50	248	10	
100	4	369	429	28	60	433	433	487	24	50	248	10	
112	5,5	391	448	28	60	456	456	511	24	50	266	10	
132	7,5	490	570	38	80	585	-	-	-	-	326	12	

These dimensions are our standard (4-pole), but can be changed in individual cases

We reserve the right to change the dimensions, without changing the designation of the motor.

Three-phase AC motors

Flange profile B5

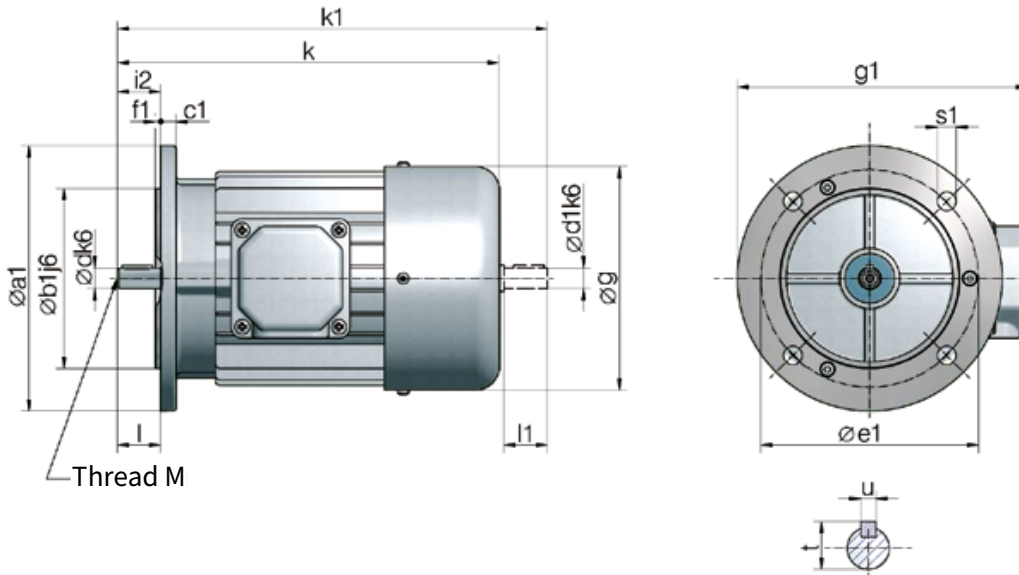

B5: Flange with through holes

Size	a1	b1	c1	e1	f1	g	i2	s1	d	l	t	u
71	160	110	130	7	3,5	141	30	9,5	14	30	16	5
80	200	130	165	8	3,5	159	40	11,5	19	40	21,5	6
90	200	130	165	8	3,5	179	50	11,5	24	50	27	8
100	250	180	215	10	4	199	60	14	28	60	31	8

112 Dimensions on request

These dimensions are standardised and therefore always the same

Size	kW	without brake				with brake		with brake and second shaft end			g1	M
	(4-pole)	k	k1	d1	l1	k	k	k1	d1	l1		
71	0,37	248	281	14	30	263	295	325	11	23	188	5
71	0,75	248	281	14	30	263	295	325	11	23	188	5
80	0,75	277	315	19	40	305	330	375	19	40	211	6
80	1,5	277	315	19	40	305	330	375	19	40	211	6
90	1,5	329	378	24	50	390	390	432	19	40	227	8
90	2,2	329	378	24	50	348	390	432	19	40	227	8
100	3	369	429	28	60	433	433	487	24	50	248	10
100	4	369	429	28	60	433	433	487	24	50	248	10

112 Dimensions on request

These dimensions are our standard (4-pole), but can be changed in individual cases

We reserve the right to change the dimensions, without changing the designation of the motor.

Three-phase AC motors

Pedestal mounted type B3

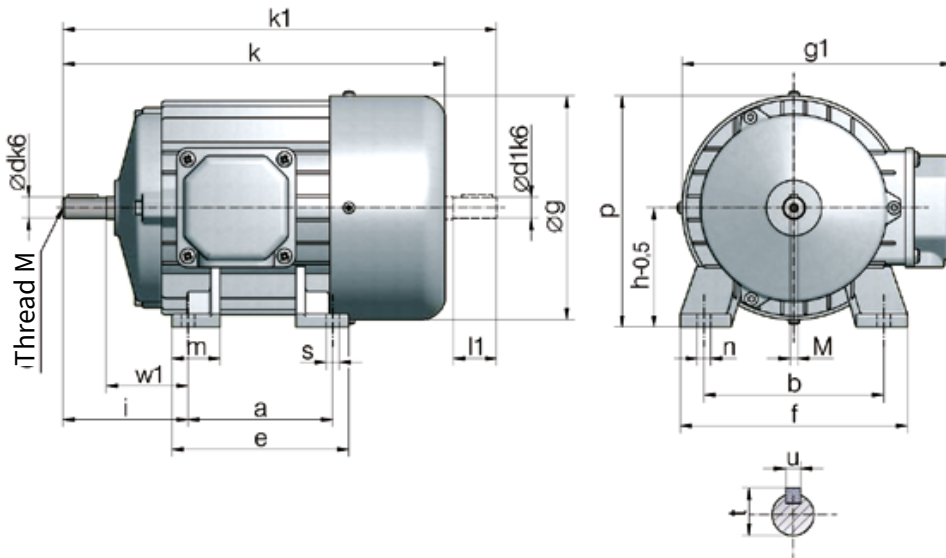

For this type, we can supply a flanged motor (e.g.: B14) with additional pedestal mounts fitted. This version is generally available on a shorter lead time. The dimensions remain the same.

Please specify the terminal box position (top, right or left when looking at the motor shaft). If not otherwise specified, we deliver up to size 112 with the box on top and from size 132 with it on the right.

Size	a1	b1	e1	c1	f1	g	i2	s1	w1	d	t	t	u
71	90	112	141	71	75	142	7	7	45	14	30	16	5
80						160			50	19		21,5	6
90						180			56	24		27	8
100	140	160	199	100	123	200	12	20	63	28	60	31	8
112	Dimensions on request												
132S	Dimensions on request												
132M	Dimensions on request												
160M	Dimensions on request												
160L	Dimensions on request												
180M	Dimensions on request												
180L	Dimensions on request												
200L	Dimensions on request												

These dimensions are standardised and therefore always the same

*The height g1 is for top-mounted terminal boxes

Size	kW	without brake					with brake					with brake and second shaft end				
	(4-pole)	k	k1	d1	l1	k	k	k1	d1	l1	g1	M	f	g1	M	
71	0,37	248	281	14	30	263	295	325	11	23	11	108	136	188	5	
71	0,75	248	281	14	30	263	295	325	11	23	11	105	136	188	5	
80	0,75	277	315	19	40	305	330	375	19	40	11	125	154	211	6	
80	1,5	277	315	19	40	305	330	375	19	40	11	125	154	211	6	
90	1,5	329	378	24	50	390	390	432	19	40	13	155	174	227	8	
90	2,2	329	378	24	50	348	390	432	19	40	13	155	174	227	8	
100	3	369	429	28	60	433	433	487	24	50	14	175	192	248	10	
100	Dimensions on request															
112	Dimensions on request															
132S	Dimensions on request															
132M	Dimensions on request															
160M	Dimensions on request															
160L	Dimensions on request															

These dimensions are our standard (4-pole), but can be changed in individual cases

Accessories

Connecting shaft VWZ | Split shells

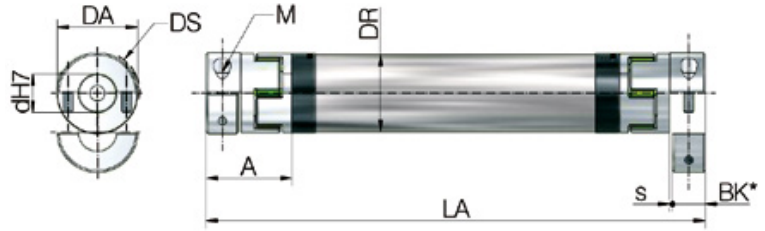
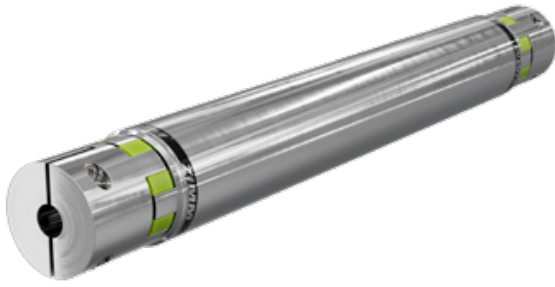

Standard bores „d“ mm

VWZ-40:	9, 10, 11, 12, 14, 15, 16, 18,19, 20, 22, 24
VWZ-60:	10, 11, 12, 14, 15, 16, 18, 19, 20, 22, 24, 25, 28, 30, 32
VWZ-60V:	12, 15, 16, 18, 20, 22, 24, 25, 28, 30, 32, 35
VWZ-80:	16, 19, 20, 22, 24, 25, 28, 30, 32, 35, 38, 40, 42, 45
VWZ-100:	25, 28, 32, 38, 40, 42, 45, 48, 50, 55

Other diameters on request

Shafts with split shells

Material:	High-tensile aluminium (stainless steel on request)
Insertion:	Split shells permit easy radial insertion
Moment of inertia:	Low
Drive key:	None. Stepless adjustment facility thanks to the clamp hub. Drive keyway available on request
Other features:	High concentricity and clamping forces

Elastomer star

Features:	Permanently free of play, dampens vibration
Shore hardness:	64D
Colour:	ZIMM-green
Temperature range:	0°C to +70°C reduced to -20°C, to +100°C (Mx0,55)

Dimensions & technical data

Code	Dimensions				Clamping screw		Moment of inertia		Torsional stiffness		Weight				
	DA	DS	DR	BK*	s	A	LA min	M	Tightening torque	per coupling	tube/m	per star	per tube/m	both couplings	tube/m
	mm	mm	mm	mm	mm	mm	mm	10,9	Nm	10 ⁻³ kgm ²	10 ⁻³ kgm ²	C _{tdyn} Nm/rad	C _{tdyn} Nm/rad	kg	kg
VWZ-40	42	44,5	40	17	1,5	46	133	M5	8	0,08	0,2	3700	2332	0,36	0,76
VWZ-60	56	57	60	30	2	63	177	M6	15	0,24	0,8	9917	8292	0,94	0,97
VWZ-60V	67	68	60	35	2	73	205	M8	35	0,46	0,8	24417	8292	1,42	0,97
VWZ-80	82	85	80	40	2	84	249	M10	70	2,4	3	33667	29102	2,98	2
VWZ-100	102	105	100	50	2	97	283	M12	120	6	5,8	67667	58178	4,62	2,47

*BK = shaft extension clamping length

Torques

Size	Elastomer star		Maxium transmittable torque by clamp hub depending on the bore diameter																	Coupling type	
	Nominal torque Nm	max. torque Nm	Ø9 Nm	Ø11 Nm	Ø14 Nm	Ø16 Nm	Ø19 Nm	Ø20 Nm	Ø22 Nm	Ø24 Nm	Ø25 Nm	Ø28 Nm	Ø30 Nm	Ø32 Nm	Ø38 Nm	Ø40 Nm	Ø42 Nm	Ø45 Nm	Ø48 Nm		Ø55 Nm
VWZ-30	16	32	21	26	33	37															KUZ-KK-16
VWZ-40	21	42	-	41	52	60	70	74	81	89	-	-	-	-	-	-	-	-	-	-	KUZ-KK-24
VWZ-60	75	150	-	60	76	87	104	109	120	131	136	153	164	175	-	-	-	-	-	-	KUZ-KK-32
VWZ-60V	200	400	-	-	-	120	-	188	206	-	235	-	-	301	-	-	-	-	-	-	KUZ-KK-35
VWZ-80	405	810	-	-	-	325	386	406	447	488	508	568	610	650	772	-	854	915	-	-	KUZ-KK-45
VWZ-100	660	1350	-	-	-	-	-	-	-	-	570	638	-	730	866	914	960	1029	1097	1250	KUZ-KK-60



Concentricity test

ZIMM VWZ shafts of 1000 mm length and more are checked for concentricity as standard!

Ordering example:

VWZ-60-LA 1800-20/25

Size _____
 Length _____
 Bores of couplings _____

n = 1500 min⁻¹ (specify the speed)

Accessories

VWZ length calculation

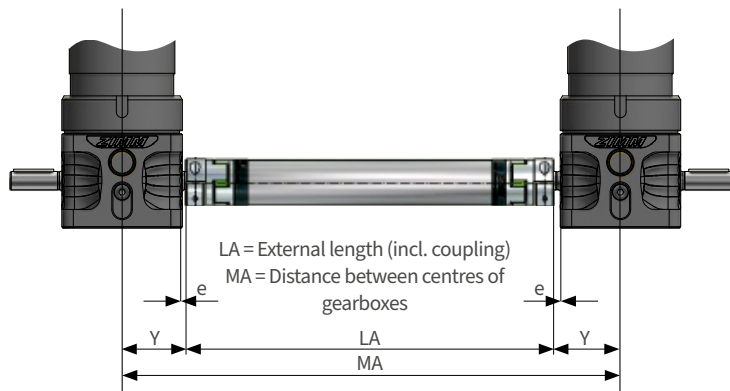

Length calculation

Screw jack	Connecting shaft	e	Y	A
ZA-25	VWZ-40	28	80,5	46
ZA-25	VWZ-60	15	67,5	63
ZA-25	VWZ-80 ^{2), 3)}	5	57,5	84
ZA-50	VWZ-60	17,5	90	63
ZA-50	VWZ-60V	12,5	85	73
ZA-50	VWZ-80 ¹⁾	7,5	80	84
ZA-100	VWZ-60	30	124	63
ZA-100	VWZ-60V	25	119	73
ZA-100	VWZ-80	20	114	84
ZA-200	VWZ-60	34	146,5	63
ZA-200	VWZ-60V	29	141,5	73
ZA-200	VWZ-80	24	136,5	84
ZA-200	VWZ-100	14	126,5	97

1) can not be fitted with pivot mounts LB 2) Outer diameter DS > Gearbox height
3) an SO coupling with shaft adapter is required for use on bevel gearboxes

Installation of the connecting shaft

By using split shell couplings, the connecting shafts can be mounted after the drive shafts have been installed.
Simply place the connecting shaft on the spigot and fix the couplings with torque wrench according to the table (feather key not required).

Set the screw tightening torque according to the table.



Maximum length – dependent on speed

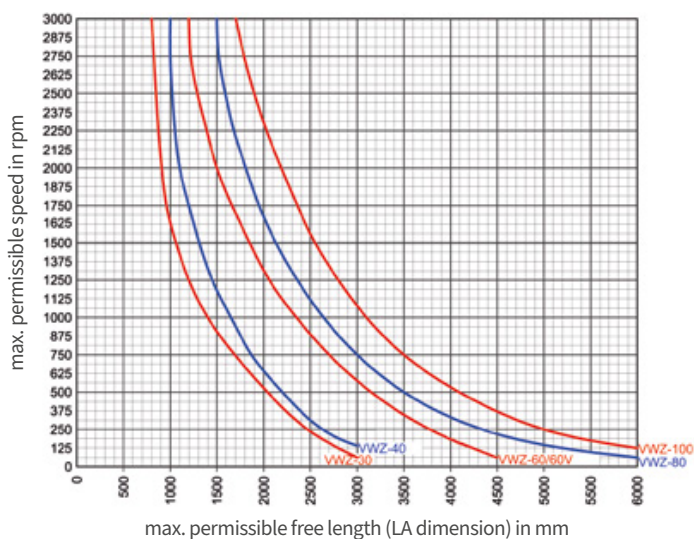

ZIMM VWZ shafts of 1000 mm length and more are checked for concentricity as standard!

max. permissible offset

Lateral offset (β):



Angular offset (R):



Axialversatz (A):



Accessories

Pedestal bearing | with flexible / rigid hub

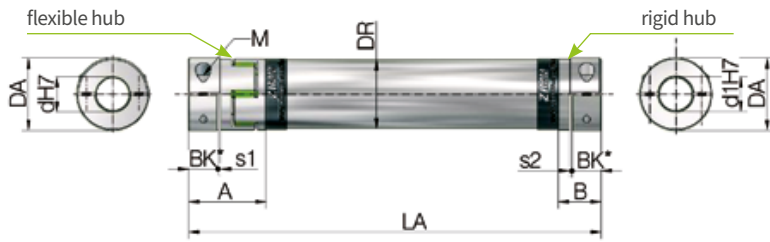

For pedestal bearing

The installation situation is very important when selecting shaft dimensions. For example, the cost of a larger diameter connecting shaft not requiring additional pedestal bearing support can be considerably less than the cost of a smaller connecting shaft requiring costly sub-structures for the additional pedestal bearing. For this version we use the rigid hub version so that no radial misalignment can occur in the pedestal bearing.

Size	A	B	s1	s2	Bk*	d1	LA min
VWZ-40	46	25	2	1,6	17	20	112
VWZ-60	63	40	2	2	30	20	154
VWZ-60V	73	42	2	2	35	30	175
VWZ-80	84	55	2	2	40	30	220
VWZ-100	97	65	2	2	50	50	251

*BK = shaft extension clamping length

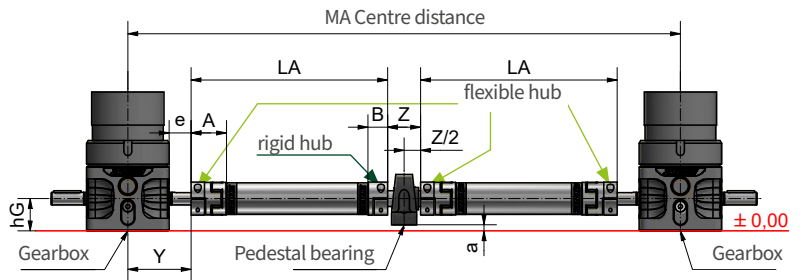

Gearbox	Connecting shaft	e	Y	A	B	Z	Lwz	d1	hG	hL	a
ZE-25	VWZ-40	28	80,5	46	25	42	76	20	41	33,2	7,8
ZE-25	VWZ-60	15	67,5	63	40	42	102	20	41	33,2	7,8
ZE-25	VWZ-80	5	57,5	84	55	50	130	30	41	42,9	-1,9
ZE-50	VWZ-60	17,5	90	63	40	42	102	20	58	33,3	24,7
ZE-50	VWZ-60V	12,5	85	73	42	60	130	30	58	42,9	15,1
ZE-50	VWZ-80*	7,5	80	84	55	50	130	30	58	42,9	15,1
ZE-100	VWZ-60	30	124	63	40	42	102	20	80	33,2	46,8
ZE-100	VWZ-60V	25	119	73	42	60	130	30	80	42,9	37,1
ZE-100	VWZ-80	20	114	84	55	50	130	30	80	42,9	37,1
ZE-200	VWZ-60	34	146,5	63	40	42	102	20	88	54	34
ZE-200	VWZ-60V	29	141,5	73	42	60	130	30	88	42,9	45,1
ZE-200	VWZ-80	24	136,5	84	55	50	130	30	88	42,9	45,1
ZE-200	VWZ-100	14	126,5	97	65	70	170	50	88	57,2	30,8

*cannot be fitted with pivot mounts LB

Ordering example: **VWZ-60-LA1800-25/20S**

Length _____
 Bore 1st side / 2nd side (S = rigid hub)
 n=1500 rpm (specify the speed)



Accessories

Pedestal bearing STL for connecting shaft VWZ

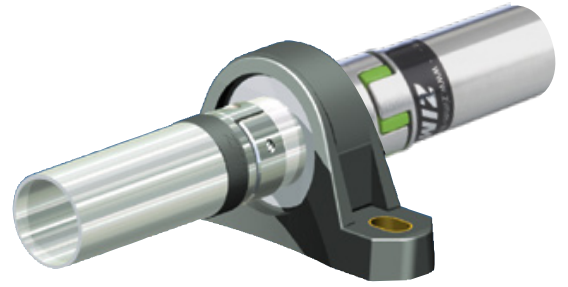

Technical data

We use high-quality pedestal bearings..
Material: Grey cast iron
Housing material: primed in blue
Bearing material: Roller bearing steel
Temperature range: -30°C to + 120°C

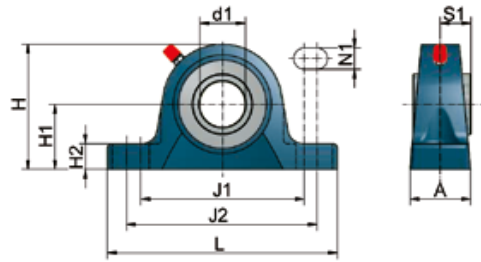
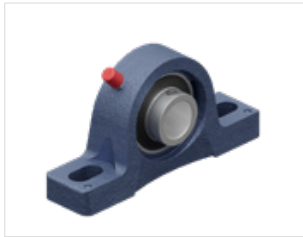

Pedestal bearing STL

Code	d1	A	H	H1	H2	J1	J2	L	N1	S1	kg
STL-15-G	15	32	56	30,2	14	88	106	127	11,5	15,3	0,47
STL-20-G	20	32	65	33,3	14	88	106	127	11,5	18,3	0,59
STL-30-G	30	40	82,5	42,9	17	108	127	152	14	22,2	1,1
STL-50-G	50	54	114,5	57,2	22	149	165	203	18	32,6	2,7

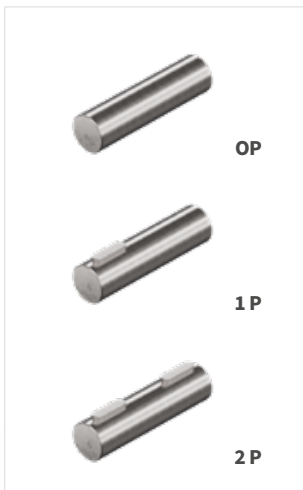

Shaft extension WZ

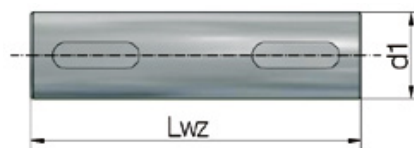

A pedestal bearing is used for long connecting shafts that are operated at higher speeds. Please pay special attention to the installation height of the pedestal bearing.

Code	d1	Lwz	kg
WZ-15/74-?P	15	74	0,1
WZ-20/76-?P	20	76	0,19
WZ-20/102-?P	20	102	0,25
WZ-30/130-?P	30	130	0,72
WZ-50/170-?P	50	170	2,61

Ordering example:

WZ-20/102-1P

Diameter _____ ↑
Bore _____ ↑
Number of keyways _____ ↑
 0P, 1P, 2P

Accessories

Standard coupling KUZ | Coupling with keyway and set screw

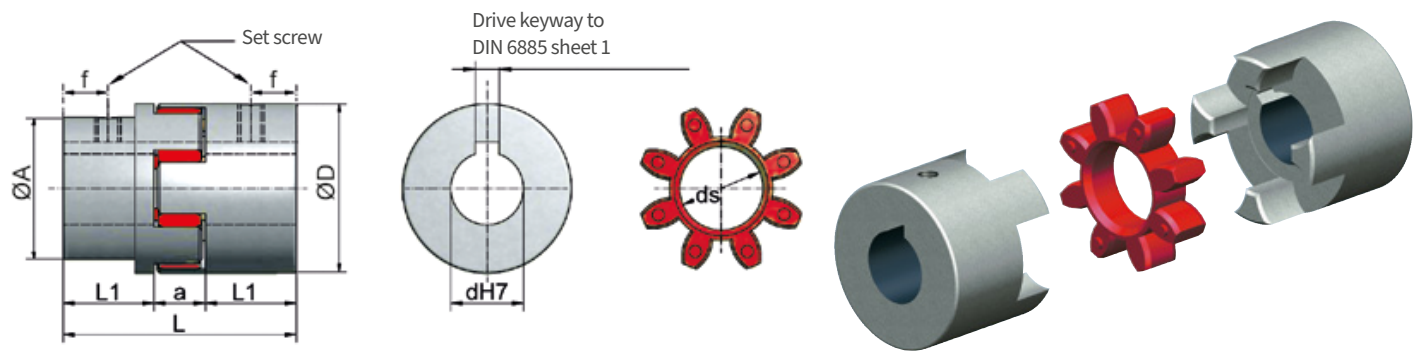

Dimensions

Size	D	A offset hub	L	L1	a	f	ds star	L1 long hub	Set screw	Tightening torque Nm
KUZ-19	34,5	-	51	19	13	9,6	12	-	M6	4,8
KUZ-24	40	-	66	25	16	10	17	40	M5	2
KUZ-28	55	-	78	30	18	10	26	-	M5	2
KUZ-38	65	-	90	35	20	15	29	60	M6	4,8
KUZ-45	80	66	114	45	24	15	37	-	M8	10
KUZ-55	95	75	126	50	26	20	45	-	M8	10
KUZ-60	105	85	140	56	28	20	50	-	M8	10
KUZ-70	120	98	160	65	30	20	59	-	M10	17
KUZ-75	135	115	185	75	35	20	67	-	M10	17
KUZ-90	160	135	210	85	40	25	79	-	M10	17

Torques

Size	Rated torque Nm	max. torque Nm	max. speed rpm	Shore hardness star	Material*	Weight drilled kg	Torsional stiffness C_{tdyn} Nm/rad	Moment of inertia $10^{-3}kgm^2$
KUZ-19	7,4	7,4	14000	92A	S	0,27	274	0,03
KUZ-24	17	34	14000	98A	S	0,34	2920	0,1
KUZ-28	60	120	10600	98A	S	0,9	9930	0,4
KUZ-38	160	320	8500	98A	S	1,5	26770	1,4
KUZ-45	325	650	7100	98A	G	2,35	48570	2,5
KUZ-55	450	900	6000	98A	G	3,55	54500	6,1
KUZ-60	625	1050	5600	98A	G	4,85	65290	10,2
KUZ-70	625	1250	4750	98A	G	7,4	94970	20,3
KUZ-75	900	1300	4250	98A	G	10,8	129510	37,1
KUZ-90	1500	3000	3550	98A	G	17,7	197500	84

S = Sintered steel, G = Cast iron

Accessories

Standard coupling KUZ | Coupling with keyway and set screw

Standard bores „d“ mm

KUZ-19:	U, 11, 14, 16, 19
KUZ-24:	U, 11, 14, 16, 19, 19L, 20, 24
KUZ-28:	U, 14, 16, 19, 20, 24, 25, 28
KUZ-38:	U, 25, 28, 28L, 32, 38
KUZ-45:	U, 25A, 28A, 32A, 38A, 42, 45
KUZ-55:	U, 28A, 38A, 40A, 42A, 48, 55
KUZ-60:	38A, 40A, 60
KUZ-70:	40A, 65

U = not drilled (KUZ-19 pre-drilled $\varnothing 6,3$ mm)
 L = long hub
 A = offset hub
 * = coupling with set screw, without keyway.
 Other diameters available on request.

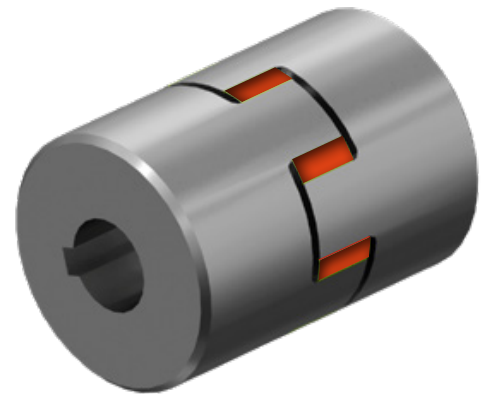

Elastomer star

Material: polyurethane
Damping: medium to good damping
Strength: very good long-term strength
Temperature range: -20°C to +70°C
 reduced to -30°C,
 up to +100°C (Mx0,55)

Coupling with keyway and set screw

Material: as shown in the tablee
Keyway: DIN 6885/1
Other features: Provides rotational resilience and maintenance-free

Permissible assembly errors

Size	A mm	R mm	β
KUZ-19	0,75	0,4	0,5°
KUZ-24	1,2	0,2	0,9°
KUZ-28	1,4	0,22	0,9°
KUZ-38	1,5	0,25	0,9°
KUZ-45	1,8	0,28	1,0°
KUZ-55	2	0,32	1,0°
KUZ-60	2,1	0,36	1,1°
KUZ-70	2,2	0,38	1,1°
KUZ-75	2,6	0,42	1,2°
KUZ-90	3	0,48	1,2°

Potential assembly errors (KUZ and KUZ-KK)

Assembly instruction	Axial displacement A	Axis offset R	Angular error β
<p>Check the angle and radial offset using straight edges in two planes</p>	<p>axial</p>	<p>lateral</p>	<p>angular</p>

Ordering example:

KUZ-24-20/24

Size _____
 Bore 1st side _____
 bore 2nd side _____

Accessories

Clamp coupling KUZ-KK | Coupling with split shells

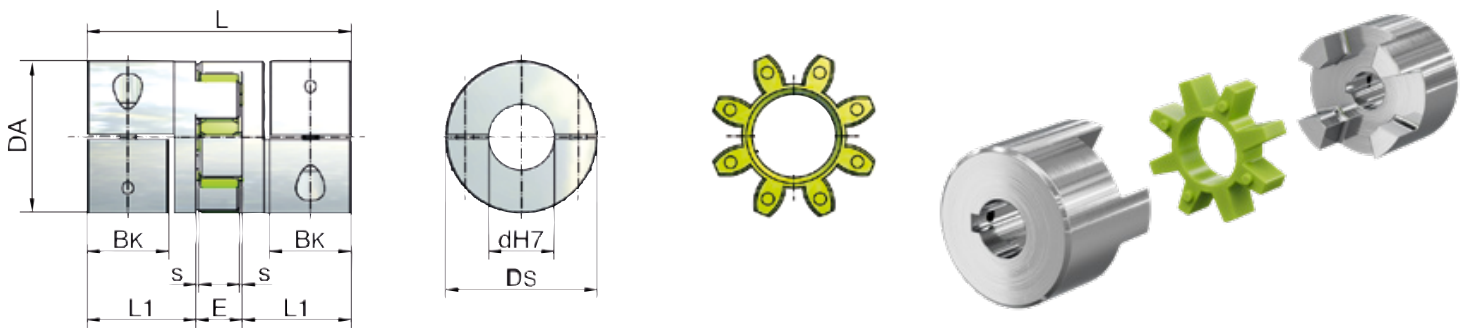

Dimensions

Size	Dimensions							Clamping screw		Moment of inertia 10 ⁻³ kgm ² "	Torsional stiffness C _{tdyn} Nm/rad	Weight kg
	DA mm	DS mm	L mm	L1 mm	BK* mm	s mm	E mm	M 10,9	Tightening torque Nm			
KUZ-KK-16	32	32	54	21	15	1,5	12	M4	4	0,01	1375	0,1
KUZ-KK-24	42	44,5	66	25	17	1,5	16	M5	8	0,08	3700	0,2
KUZ-KK-32	56	57	98	40	30	2	18	M6	15	0,24	9917	0,55
KUZ-KK-35	67	68	114	47	35	2	20	M8	35	0,51	24417	0,9
KUZ-KK-45	82	85	134	55	40	2	24	M10	70	2,4	33667	1,6
KUZ-KK-60	102	105	156	65	50	2	26	M12	120	6	67667	2,7

*BK = shaft extension clamping length

Technical data

Size	Elastomer star		Maximum transmittable torque of clamp hub depending on the bore diameter (clamp force)																	
	Rated torque Nm	max. torque Nm	Ø9 Nm	Ø11 Nm	Ø14 Nm	Ø16 Nm	Ø19 Nm	Ø20 Nm	Ø22 Nm	Ø24 Nm	Ø25 Nm	Ø28 Nm	Ø30 Nm	Ø32 Nm	Ø38 Nm	Ø40 Nm	Ø42 Nm	Ø45 Nm	Ø48 Nm	Ø55 Nm
KUZ-KK-16	16	32	21	26	33	37	-	-	-	-	-	-	-	-	-	-	-	-	-	-
KUZ-KK-24	21	42	-	41	52	60	70	74	81	89	-	-	-	-	-	-	-	-	-	-
KUZ-KK-32	75	150	-	60	76	87	104	109	120	131	136	153	164	175	-	-	-	-	-	-
KUZ-KK-35	200	400	-	-	-	120	-	188	206	-	235	-	-	301	-	-	-	-	-	-
KUZ-KK-45	405	810	-	-	-	325	386	406	447	488	508	568	610	650	772	-	854	915	-	-
KUZ-KK-60	660	1350	-	-	-	-	-	-	-	-	570	638	-	730	866	914	960	1029	1097	1250

The max. torque is limited either by the star or by the clamping force

Accessories

Clamp coupling KUZ-KK | Coupling with split shells

Standard bores „d“ mm

KUZ-KK-16:	8, 9, 10, 11, 12, 14, 15, 16
KUZ-KK-24:	9, 10, 11, 12, 14, 15, 16, 18, 19, 20, 22, 24
KUZ-KK-32:	10, 11, 12, 14, 15, 16, 18, 19, 20, 22, 24, 25, 28, 30, 32
KUZ-KK-35:	12, 15, 16, 18, 20, 22, 24, 25, 28, 30, 32, 35
KUZ-KK-45:	16, 19, 20, 22, 24, 25, 28, 30, 32, 35, 38, 40, 42, 45
KUZ-KK-60:	25, 28, 32, 38, 40, 42, 45, 48, 50, 55

Other diameters available on request
Keyway available on request



Coupling with split shells

Material:	Hochwertiges Aluminium
Keyway:	Keine, stufenlos einstellbar durch Klemmnabe statt Passfeder Passfeder auf Anfrage
Insertion:	Bequemer radialer Einbau durch Halbschalen
Other features:	Hohe Rundlaufgenauigkeit Hohe Klemmkräfte Geringes Massenträgheitsmoment

Elastomer star

Material:	Polyurethane
Shore-hardness:	64D
Colour:	ZIMM green
Other features:	Permanently free of play, dampens vibration Temperature range: -20°C to +70°C reduced to -30°C, to +100°C (Mx0,55)

Permissible assembly errors

Size	A mm	R mm	β
KUZ-KK-16	±1	0,08	1°
KUZ-KK-24	±2	0,08	1°
KUZ-KK-32	±2	0,1	1°
KUZ-KK-35	±2	0,15	1°
KUZ-KK-45	±2	0,12	1°
KUZ-KK-60	±2	0,14	1°

Figure "Potential assembly errors" see previous page.

Potential assembly errors (KUZ and KUZ-KK)

Assembly instruction	Axial displacement A	Axis offset R	Angular error β
<p>Check the angle and radial offset using straight edges in two planes</p>	<p>axial</p>	<p>lateral</p>	<p>angular</p>

Ordering example:

KUZ-KK-32-20/24

Size _____ ↑ ↑ ↑
Bore 1st side _____ ↑ ↑
Bore 2nd side _____ ↑

Bevel gearboxes

KSZ-H | T + L-Version with spiral-toothed

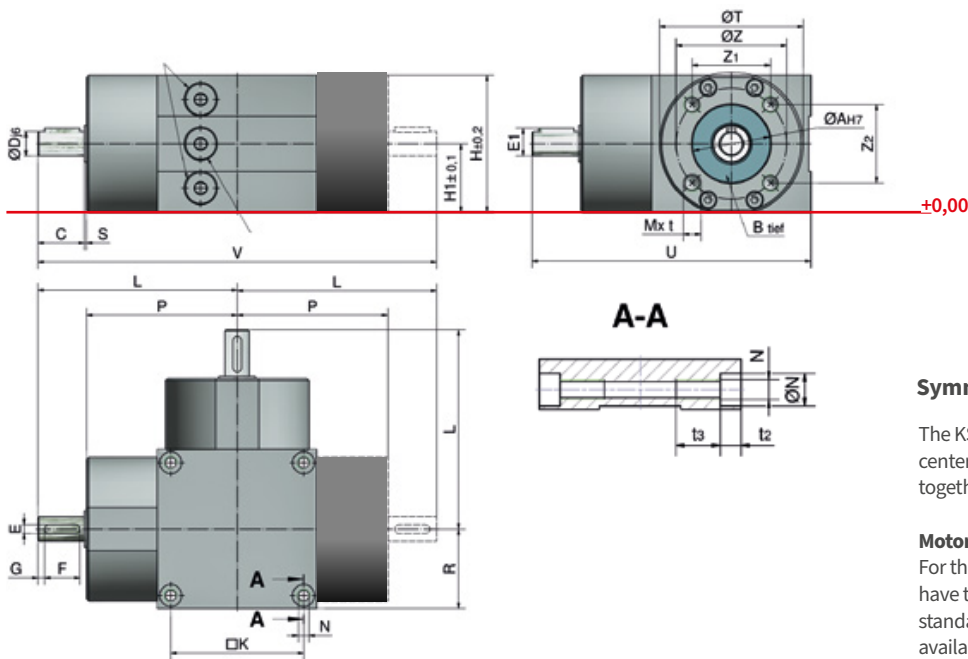

Symmetry

The KSZ-H bevel gearboxes can be rotated about the center axis in all directions and can also be bolted together.

Motor flange & motor mounting

For the motor flange, bevel gearboxes and actuators have the same hole pattern. There is a wide range of standard IEC motor flanges for easy motor mounting available from ZIMM.

Dimensions

Code	ØAH7	B	C	Dj6	Eh9	E1	F	G	H	H1	K	L	M	t	N	ØN	t2	t3	P	R	S	ØT	U	V	ØZ	Z1	Z2
KSZ-H-25-L/T	42	3	27	16	5	18	22	3	82	41	78	117	M10	15	M8	11	8,2	25	88,5	47,5	1,5	91 ³	164,5	234	71,7	62	36
KSZ-H-50-L/T	52	4	39	20	6	22,5	32	3	116	58	110	165	M10	20	M12	20	12,6	30	124	67,5	2	126 ⁵	232,5	330	86	50	70
KSZ-H-100-L/T	62	4	45	32	10	35	40	3	160	80	154	235	M12	22	M12	20	12,6	35	188	94	2	170 ⁶	329	470	106,5	46	96
KSZ-H-150-L/T	62	5	53	38	10	41	50	1,5	185	92,5	180	275	M12	22	M16	26	15,1	40	220	110	2	188 ⁷	385	550	106,5	46	96

Material: EN-GJL-200 (GGL-20), corrosion resistant, bolt: stainless steel, sealing by means of shaft seals and O-rings.

ØT Flattening: 1) 61 mm 2) 73 mm 3) 80 mm 4) 99 mm 5) 115 mm 6) 159 mm 7) 184 mm

Same mounting height as our screw jacks – no support plates required

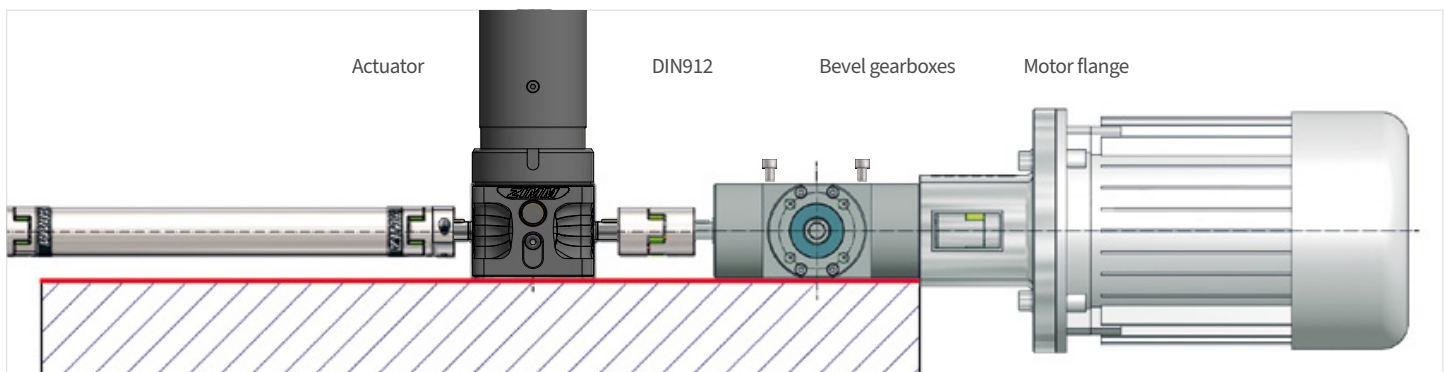

Same mounting height as the actuators in the same size

The ZIMM bevel gearboxes KSZ-H have the same fitting height as the ZIMM actuators. No support plates are required. Furthermore, they are dimensionally compatible with the previous KSZ and KGZ types. If a larger bevel gearbox has to be used due to a high torque, the difference in height must be compensated structurally by means of shims or similar.

Additional attachment options

Besides the standard internal threads for screw connection from below, the special design of the bores now also permits screw connection from above. DIN 912 hexagon socket head screws can be used. A wide selection of standard IEC motor flanges of the ZIMM screw jacks are available to ensure simple motor mounting.



Technical data

Quality features & advantages of the KSZ-H series

Features of the KSZ-H bevel gearhead series include high precision and torque, and a high-quality two-component paint finish that provides effective corrosion protection.

- + Low-backlash version
- + Quiet running
- + High torque transmission in a small size
- + Pre-loaded taper roller bearings
- + Sealing by means of shaft seals and O-rings
- + Permanent lubrication with oil; oil change required only on heavy duty applications

Technical data overview

- Housing material:** EN-GJL-200 (GGL 20), corrosion resistant
- Bevel gears:** Spiral-toothed
- Installation axis/Dimensions:** All-sided, symmetrical with actuator mounting position any, or in all directions possible.
- Duty factor:** Max. 40% at 1500 min⁻¹
- Drive ratio:** 1:1, 2:1, 3:1
- Temperature range:** -10C to +90C

Technical data

Screw jacks	i	Permissible torque Nm at various speeds rpm					Moment of inertia kg cm ²		F radial N	Weight kg	
		100	500	1000	1500	3000	L	T		L	T
KSZ-H-25-L/T	1:1	72	71	60	52,5	42	3,38	4,215	300	7,2	9,1
	2:1	41	40	40	40	38	3,38	4,215	300	7,2	9,1
	3:1	34	34	33,5	33,5	33	3,38	4,215	300	7,2	9,1
KSZ-H-50-L/T	1:1	162	160	158	155	125	11,586	16,269	1100	17	21,4
	2:1	145	144	143	141	115	11,586	16,269	1100	17	21,4
	3:1	100	100	99	98	93	11,586	16,269	1100	17	21,4
KSZ-H-100-L/T	1:1	507	466	455,5	450,5	370	107,8	126,074	1600	54	70,6
	2:1	410	410	400	400	320	107,8	126,074	1600	54	70,6
	3:1	315	315	313	311	305	107,8	126,074	1600	54	70,6
KSZ-H-150-L/T	1:1	781	719,4	703,6	680	540	206,407	236,908	2500	82,1	103
	2:1	675	670	664	657	555	206,407	236,908	2500	82,1	103
	3:1	500	497	494	490	435	206,407	236,908	2500	82,1	103

Instruction on the direction of rotation of the shaft configuration

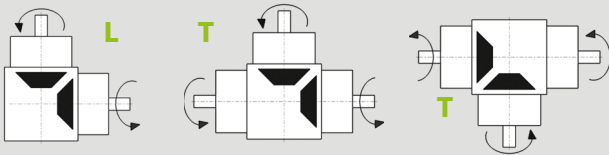

Direction of rotation

To change the direction of rotation, the bevel gearboxes can be rotated by 180°. Since the gears are symmetrical, it can be rotated around the Z-axis as well as on the Y-axis.

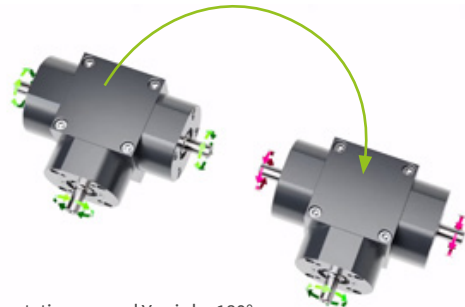

When rotating around Y axis by 180° the direction of rotation changes.

Ordering example:

KSZ-H-50-T-1:1





Bevel gearbox accessories

Motor flange combinations | KSZ-H 25 to 100

Motor flange MF
KSZ-H-5 to KSZ-H-25

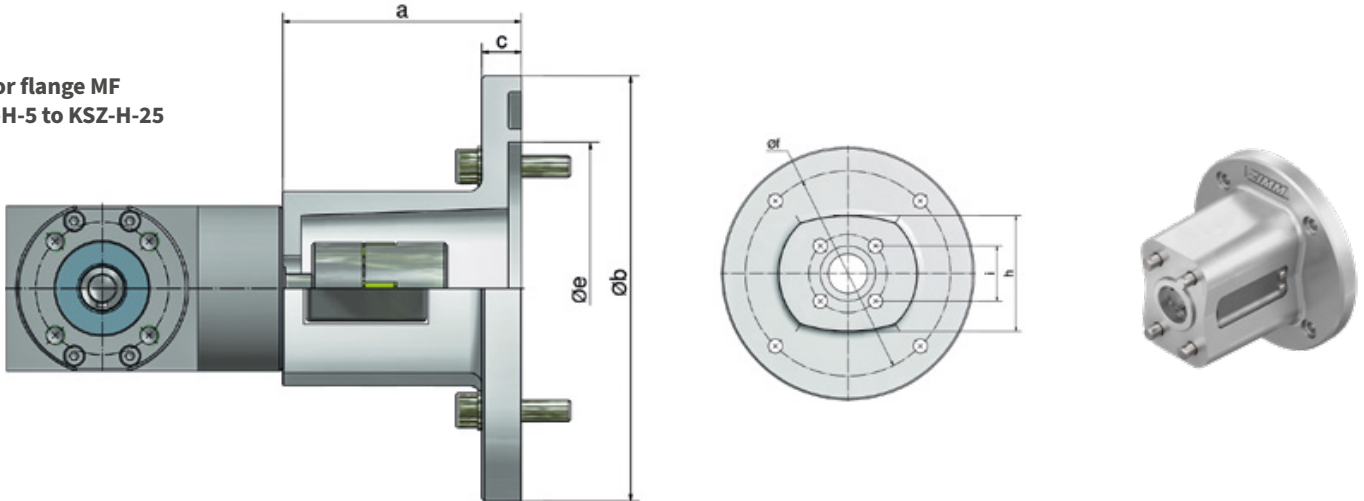

Motor flange base MF-B and motor flange plate MF-P - KSZH-50 to KSZH-150 (2 pieces)

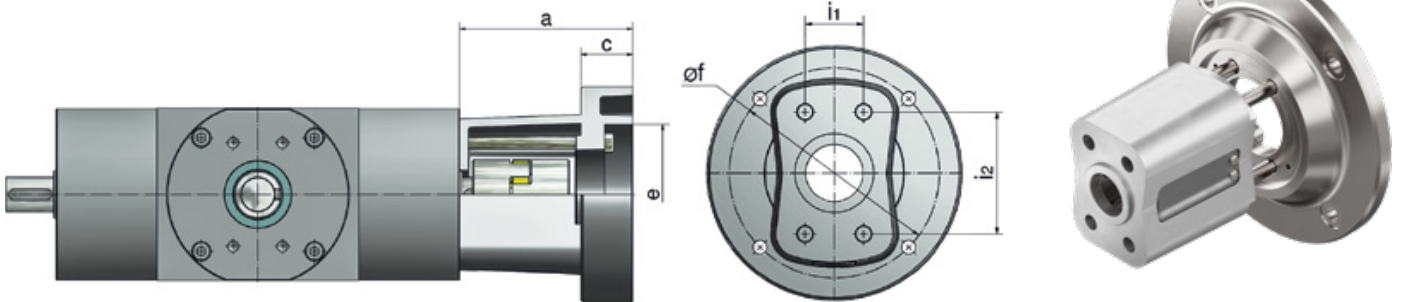

Size	Code	Motor Type	Coupling Code		4 of Screws gearbox side 8.8 DIN *	4 of socket head cap screws 8.8 DIN 912	a	b	c	e	f	h/i1	i/i2	kg	Transmittable torque Nm ³⁾		
			Bore - Ø												Rated.	max.	
KSZ-H-25	ZE-35-MF-160-111	80 B14B	KUZ-24	16	19L	M10x30	M8x25 ¹⁾	111	160	15	110	130	36	62	2,7	17	34
KSZ-H-25	ZE-35-MF-160-111	90 B14B	KUZ-24	16	24	M10x30	M8x25 ¹⁾	111	160	15	110	130	36	62	2,7	17	25,9
KSZ-H-25	ZE-35-MF-B + ZE-35-MF-P-200	100 B14B	KUZ-28	16	28	M10x120	M10x30 ¹⁾	123	200	12	130	165	36	62	3,6	25,9	25,9
KSZ-H-25	ZE-35-MF-B + ZE-35-MF-P-200	112 B14B	KUZ-28	16	28	M10x120	M10x30 ¹⁾	123	200	12	130	165	36	62	3,6	25,9	25,9
KSZ-H-25	ZE-35-MF-B + special plate	Servomotors, geared motors, Nema, ...															

Material: Aluminium, all screws galvanized nut DIN 934
From KSZ-H-25 are screws in DIN 912.
and spring washers DIN 128. Delivery incl. screws.

1) incl. spring washers
2) incl. nuts
3) is only valid for this combination. CAUTION: Permissible torque of the respective KSZ-H must be observed.

Size KSZ-H	Code	Motor-Type	Coupling Code		4 of screws gearbox side DIN 912	4 of screws motor side DIN 912	a	b	c	e	f	i1	i2	kg	Transmittable torque Nm ⁴⁾		
			Bore - Ø												Rated.	max.	
KSZ-H-50	ZE-50-MF-200-116	90 B5	KUZ-28	20	24	M10x30	M10x45 ¹⁾	116	200	20	130	165	50	70	4,1	60	118
KSZ-H-50	ZE-50-MF-200-116	100 B14B	KUZ-28	20	28	M10x30	M10x35 ¹⁾	126	200	20	130	165	50	70	4,3	60	118
KSZ-H-50	ZE-50-MF-200-126	112 B14B	KUZ-28	20	28	M10x30	M10x35 ¹⁾	126	200	20	130	165	50	70	4,3	60	118
KSZ-H-50	ZE-50-MF-B + special plate	Servomotors, geared motors, Nema, ...															
KSZ-H-100	ZE-100/150-MF-200-138	100 B14B	KUZ-38	32	28	M12x40 ³⁾	M10x35 ¹⁾	138 ³⁾	200	20	130	165	46	96	5,2	160	164
KSZ-H-100	ZE-100/150-MF-200-138	112 B14B	KUZ-38	32	28	M12x40 ³⁾	M10x35 ¹⁾	138 ³⁾	200	20	130	165	46	96	5,2	160	164
KSZ-H-100	ZE-100/150-MF-B + P-200	132 B14C	KUZ-38	32	38	M12x150 ³⁾	M10x65 ¹⁾	161 ³⁾	200	48	130	165	46	96	8,7	160	164
KSZ-H-100	ZE-100/150-MF-B + special plate	Servomotors, geared motors, Nema, ...															
KSZ-H-150	ZE-100/150-MF-200-138	100 B14B	KUZ-38	38	28	M12x40 ³⁾	M10x35 ¹⁾	138 ³⁾	200	20	130	165	46	96	5,2	160	266
KSZ-H-150	ZE-100/150-MF-200-138	112 B14B	KUZ-38	38	28	M12x40 ³⁾	M10x35 ¹⁾	138 ³⁾	200	20	130	165	46	96	5,2	160	266
KSZ-H-150	ZE-100/150-MF-B + P-200	132 B14C	KUZ-38	38	38	M12x150 ³⁾	M10x65 ¹⁾	161 ³⁾	200	48	130	165	46	96	8,7	160	246

Material: GGG-50, corrosion-resistant, all screws galvanized nut DIN 934 and spring washers DIN 128, Delivery incl. screws.

1) incl. spring washers
2) incl. nuts and spring washers
3) Threaded bolt 8.8 with nuts and spring washers

4) is only valid for this combination. CAUTION: Permissible torque of the respective KSZ-H must be observed.

Technical information

Innovative separate lubrication | Lubricants for screw and gearbox

Automatic relubrication

Automatic relubrication (e.g. PLC-capable lubricator) must be position-controlled. This is connected to one of the two lubrication points. The opposite side is designed as a ventilation system. The ventilation must always be positioned at the top.

ACHTUNG:



Higher idle and breakaway torques are generally to be expected at low temperatures.

Langlebige Anlagen

Depending on the applications we recommend complete cleaning and regreasing after 5 years.



1

Gearbox

The gearbox is sealed and filled with a synthetic grease or fluid grease, depending on the version.

2

- Trapezoidal threaded spindle Tr
- Ball screw drive KGT
- Anti-rotation lock VS

Relubrication must be carried out in the respective lubrication positions provided for this purpose (SP1, SP2, ...)*. Lubrication quantities and intervals are application-related. For additional information, see the ZIMM actuator operating instructions (available online).

The VS anti-rotation device will also be lubricated when lubricating the spindle.

*Lubrication position, see dimensions-spec sheets from 6 onwards.

Thread/Gear	Suitable Series	Lubrication-Type	Suitability
Trapezoidal screw Tr	Spindle grease for Tr	Tungrease BS	Synthetic grease for high performance application
Ball screw KGT	Standard grease for KGT	Tribol GR 4747/220-2HT	
Gearbox fluid grease	Standard grease for gearbox, food grade grease	Optileb GR UF 00	Very high quality, synthetic grease for all standard applications with NSF-H1-approval

Other greases

Using multipurpose greases and other greases can significantly impair operation and shorten the service life.

Technical information

Permissible loads | Fastenings & mounting

The screw jacks themselves are specified for full static nominal load under tension and compression. The permissible load depends on the type of fastening.

Compressive load (fixed)

Full nominal load

The actuators can accept the full static rated load.

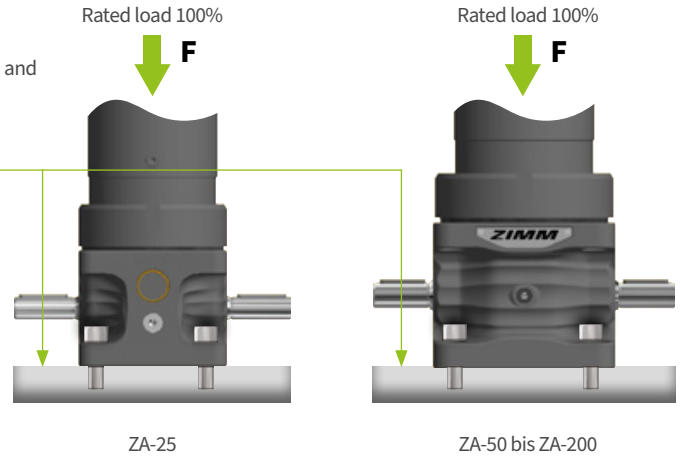

Tensile load (fixed)

Full nominal load

Tensile load on the fixing screws (through holes in the housing).

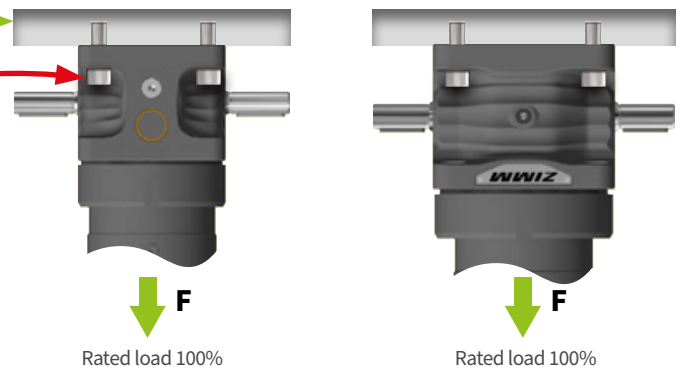
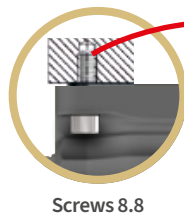

Detailed enquiry?

Our checklists help

If you would like to specify your enquiry in detail, then our checklists are at your disposal.

You can simply download these as a PDF and then add them to your online enquiry.

zimm.com

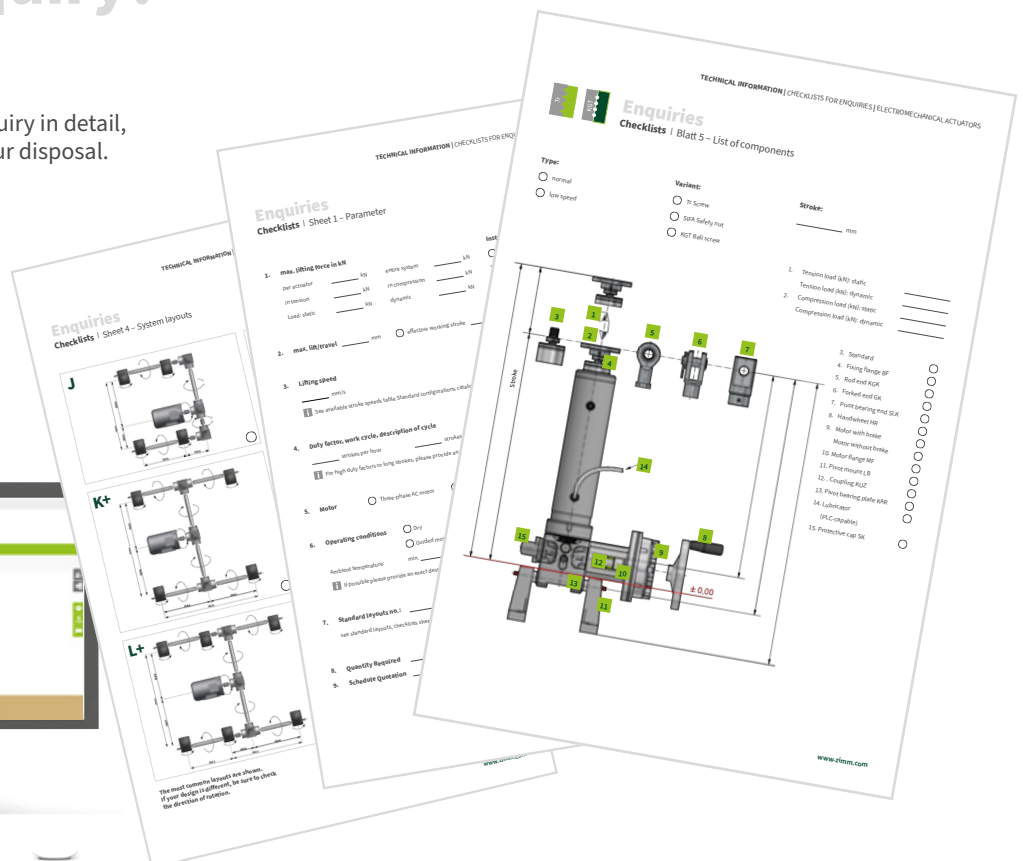

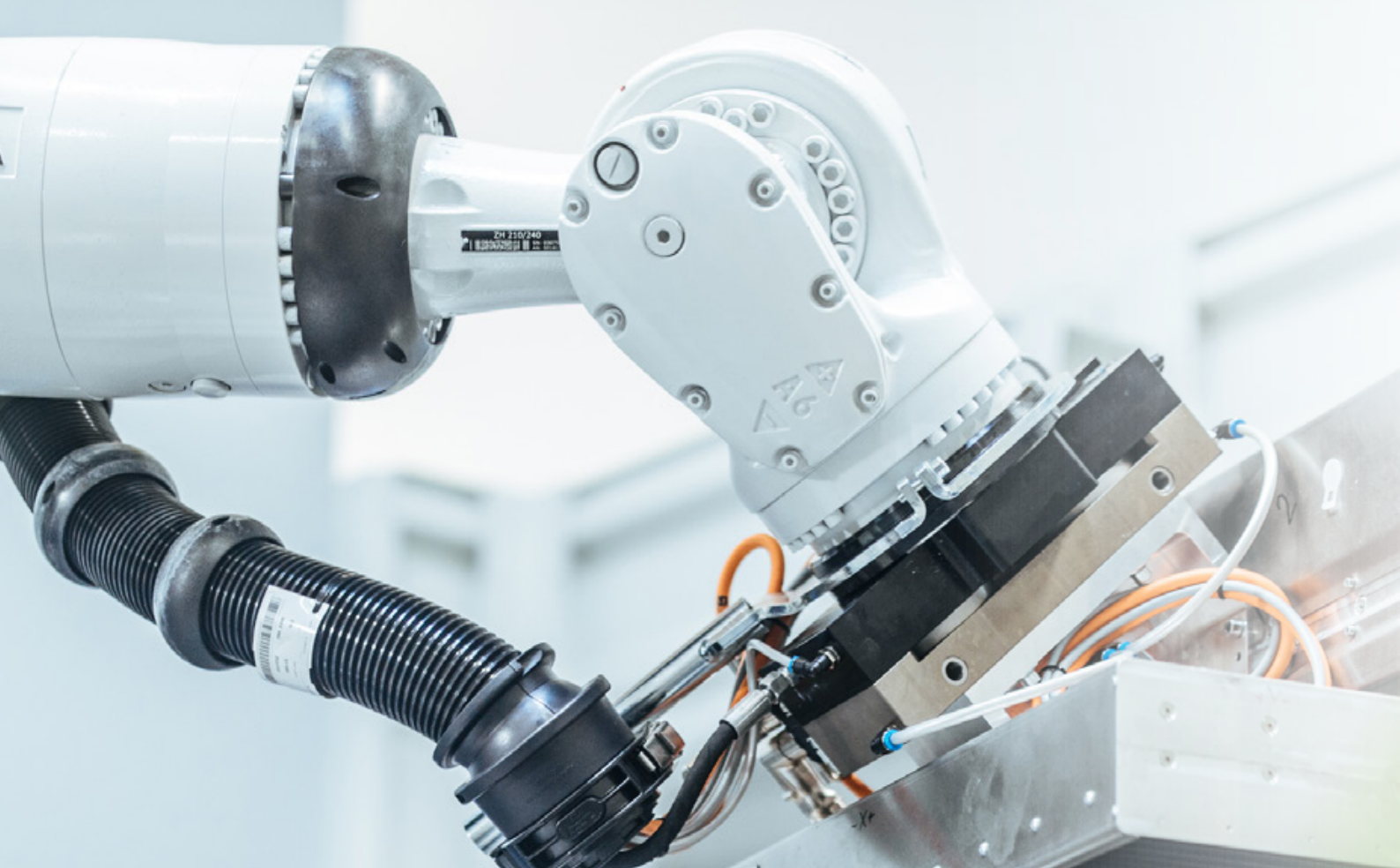

Movement with precision

ZIMM company

As the European market leader, we offer you a unique range of screw jack systems and, as of 2023, also electromechanical actuators.

There are five decades of experience within each ZIMM screw jack. Since 1991, we have been systematically improving our know-how regarding our ZIMM modular system to meet your requirements as a customer faster, more precisely, and more reliably than one may at first expect. ZIMM is delighted to improve our gearboxes and thankful to continue our success constantly. At ZIMM, you receive solutions that have been proven repeatedly and have therefore convinced well-known machine builders and industrial companies in countless industries to rely on ZIMM. Our robust integrated systems, based on the ZIMM modular system combined with customer-specific designs, are used anywhere loads must be controlled and positioned precisely – whether the load is just a few kilograms or hundreds of tonnes per gearbox. As an owner-managed family company, it is our concern to supply you with the best tools in the industry and outstanding delivery reliability.



The top 5 arguments for ZIMM

1

Flawless design in half the time

- Massive time saving in design
- Complete systems with all drives and connections
- Software prevents design errors
- Generate and download CAD in real time

2

Most extensive modular system

- Proven standard customised components
- More than 7,000 useful combination options
- Engineering service for special requirements

3

Pioneering product design

- Continuous improvement and further development
- Harmonious design also for a visible installation
- Well thought-out details and product advantages
- Standardised interfaces and installation sizes

4

Proven and tested quality

- Standard anti-corrosion protection
- Comprehensive test, measurement and inspection systems
- ISO 9001: 2015 certified

5

Reliable and fast delivery

- Order processing via website possible
- Flexibility and capacity for large quantities
- High delivery reliability

Our gearbox range

With lifting forces from 2.5 to 1000 kN in 14 different sizes

in trapezoidal thread design from Tr 16x4 to 160x20

in ball screw design from KGT 16x5 to 160x80

Series/Load	2,5 kN	5 kN	10 kN	25 kN	35 kN	50 kN	100 kN
ZE Series Newest technology Highly dynamic requirements and speeds of up to 3000 min ⁻¹ in combination with ball screws. 100% compatible with the previous Z-Series. Proven and improved once again.							
ZA-Series Electromechanical ZIMM actuators As with all lifting systems, the same add-on parts from the ZIMM modular system can be used for the electromechanical actuators.							
GSZ Series Cubic series These cubic worm gear screw jacks from ZIMM are characterised by a smooth surface. Compatible with "SHZ" and "MSZ"							
Drive ratios		4:1 16:1		6:1 24:1		7:1 28:1	9:1 36:1

Download the comprehensive screw jack product catalogue.
 All sizes, thermal data, technical information and calculation,
 as well as the complete ZIMM modular system including all add-on parts.

More on our download page at zimm.com

150 kN	200 kN	250 kN	350 kN	500 kN	750 kN	1000 kN
						
						
						
9:1 36:1	8:1 24:1		10,66:1 32:1		13,33:1 40:1	

Worldwide in use

**Global service
in 37 countries**



ZIMM GmbH
Lustenau, Austria

Corporate headquarters of the ZIMM Group
Development, production and sales of
industrial gearboxes and matching parts

ZIMM USA Inc.
Bloomingdale/Chicago

Sales and
service office

ZIMM Turkey
Ankara, Turkey

Casting, series production
and mechanical processing

ZIMM Group GmbH

Millennium Park 3,
6890 Lustenau/Austria
T +43 5577 806-0, E info@zimm.com

zimm.com